



ELECTRUM AV

www.electrum-av.com

01.01.2013
MT16, MT16PT

**MODULES FOR DC AND AC COMMUTATION
MT16, MT16PT**

USER'S MANUAL



CONTENTS

1. APPLICATION AND PRODUCED MODULES.....	3
2. GENERAL DESCRIPTION.....	4
3. BASIC PARAMETERS.....	5
4. INSTRUCTIONS FOR USE.....	10
6. OVERALL AND CONNECTING DIMENSIONS.....	12

This document is a user's manual with a description of characteristics of this product for which are warranted. All the products in the production process pass a complete set of electrical tests, which are performed twice, once before encapsulation, and then again after it. Tests carried out by "Electrum AV" are exhaustive and include 100% control at the final testing.

Any such warranty is provided only in accordance with the terms of the supply agreement (supply contract or other documents in accordance with applicable law). The information presented in this document does not provide warranties and liability of "Electrum AV" by the use of such information and the suitability of products for your equipment. The data contained in this document are intended exclusively for technically trained staff. You and your technical expert will have to evaluate the suitability of the product for the application and the completeness of the product data, in connection with this application.

Any products of "Electrum AV" are not permitted for the use in devices and life support systems and special equipment without the prior written consent of "Electrum AV".

If you need information about the product, which is not shown in this user's manual or which concerns the specific application of our product, please contact the sales office to the manager who is responsible for your enterprise.

Engineers "Electrum AV" have a lot of experience in the design, manufacture and application of powerful force devices and smart drivers and has already implemented a large number of individual decisions. If you need power modules and drivers that are not included in the package, as well as products with differences from the standard devices in specifications or design, please contact to our managers and specialists who will offer you best solution for your application.

"Electrum AV" reserves the right to make changes without notice in this document to improve the reliability, functionality and design improvement.

1. APPLICATION AND PRODUCED MODULES

Modules for DC and AC commutation (semiconductor normally opened bipolar relay with transformer decoupling with low current and low switch-on time) MT16 и MT16PT are intended to use in automatics devices as a commutating element with maximum peak voltage up to 1200 V and DC up to 300 A. The modules for DC and AC commutation (hereinafter modules) are represented with the following versions:

MT16A – a module based on MOSFET or IGBT-transistor shunted with reverse fast-recovery diodes with control voltage 4...10 V.

MT16B – a module based on MOSFET or IGBT-transistor shunted with reverse fast-recovery diodes with control voltage 10...30 V.

By the power switch types the modules MT16A(B) are represented with the following versions (specified maximum permissible values of currents and voltages):

Peak voltage 60 V with an amount of DC 10,20,40,60,80,120,200,300 A.

Peak voltage 100 V with an amount of DC 5,10,20,40,60,80,120,160,200,240 A.

Peak voltage 200 V with an amount of DC 5,10,20,40,60,80,120,160,200 A.

Peak voltage 250 V with an amount of DC 5,10,20,30,40,60,80,120 A.

Peak voltage 600 V with an amount of DC 5,10,20,30,40,60,80,120,160 A.

Peak voltage 1200 V with amount of DC 5,10,20,30,40,60,80,120 A.

MT16PTA – a module based on MOSFET or IGBT-transistor shunted with reverse fast-recovery diodes with control voltage 4...10 V, with inbuilt protections against overvoltage and overcurrent.

MT16PTB – a module based on MOSFET or IGBT-transistor shunted with reverse fast-recovery diodes with control voltage 10...30 V, with inbuilt protections against overvoltage and overcurrent.

By types of power switch the modules of MT16PTA(B) are represented with following versions (specified maximum permissible values of currents and voltages):

Peak voltage 60 V with an amount of DC 5,10,20,30,40 A.

Peak voltage 100 V with amount of DC 5,10,20,30 A.

Peak voltage 200 V with an amount of DC 5,10,20,30,40 A.

Peak voltage 250 V with an amount of BC 5,10,20,30 A.

Peak voltage 600 V with an amount of DC 5,10,20,30,40 A.

Peak voltage 1200 V with an amount of DC 5,10,20,30,40 A.

Depending on the current and version the modules MO16 are produced in the versions that are represented in Table 1.1. The modules are produced only in the versions where at crossing the class line (peak voltage of power switch, maximum permissible one) of the module and the current column is specified the overall dimension corresponding to the version.

Table 1.1 – Produced modules MT16 and corresponding to them overall dimensions

Type	Class	Current, A											
		5	10	20	30	40	60	80	120	160	200	240	300
MT16	0,6		Fig.6.1	Fig.6.1		Fig.6.1	Fig.6.1	Fig.6.2	Fig.6.2		Fig.6.2		Fig.6.2
	1	Fig.6.1	Fig.6.1	Fig.6.1		Fig.6.1	Fig.6.2	Fig.6.2	Fig.6.2	Fig.6.2	Fig.6.2	Fig.6.2	
	2	Fig.6.1	Fig.6.1	Fig.6.1		Fig.6.1	Fig.6.2	Fig.6.2	Fig.6.2	Fig.6.2	Fig.6.2		
	2,5	Fig.6.2	Fig.6.2	Fig.6.2	Fig.6.2	Fig.6.2	Fig.6.2	Fig.6.2	Fig.6.2	Fig.6.2			
	6	Fig.6.1	Fig.6.1	Fig.6.2	Fig.6.2	Fig.6.2	Fig.6.2	Fig.6.2	Fig.6.2	Fig.6.2	Fig.6.2		
	12	Fig.6.2	Fig.6.2	Fig.6.2	Fig.6.2	Fig.6.2	Fig.6.2	Fig.6.2	Fig.6.2	Fig.6.2			
MT16PT	0,6	Fig.6.3	Fig.6.3	Fig.6.3	Fig.6.2	Fig.6.3							
	1	Fig.6.3	Fig.6.3	Fig.6.3	Fig.6.3								
	2	Fig.6.3	Fig.6.3	Fig.6.3	Fig.6.3	Fig.6.3							
	2,5	Fig.6.3	Fig.6.3	Fig.6.3	Fig.6.3								
	6	Fig.6.3	Fig.6.3	Fig.6.3	Fig.6.3	Fig.6.3	Fig.6.3						
	12	Fig.6.3	Fig.6.3	Fig.6.3	Fig.6.3	Fig.6.3	Fig.6.3						

On Figure 1.1 is shown modules' names explanation.

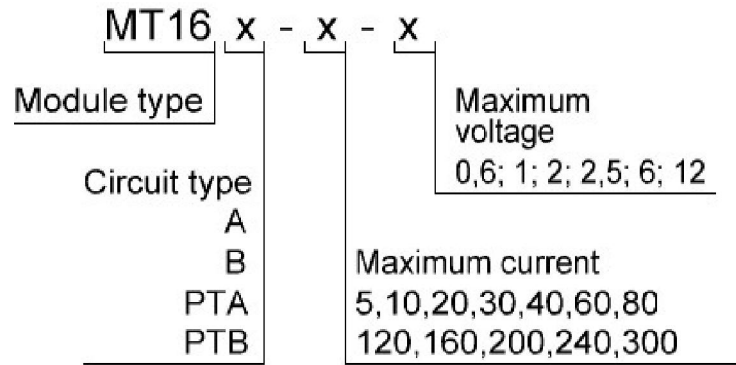

Figure 1.1 – Modules names explanation

For example, module MT16A-80-12: a module with control voltage 4...10 V, with maximum permissible collector-emitter voltage 1200 V and maximum DC 80 A.

2. GENERAL DESCRIPTION

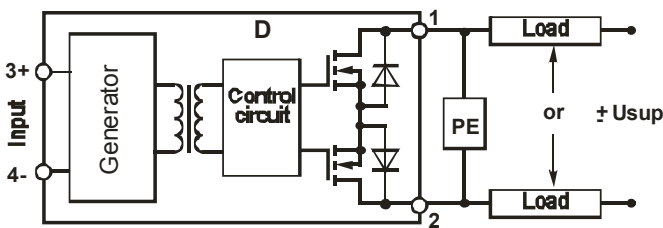

Figure 2.1 – Functional circuit MT16 (figure 6.1)

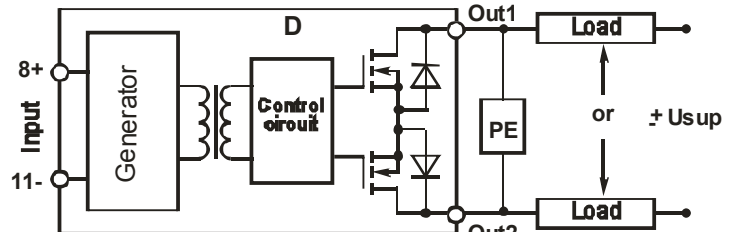

Figure 2.2 – Functional circuit MT16 (figure 6.2)

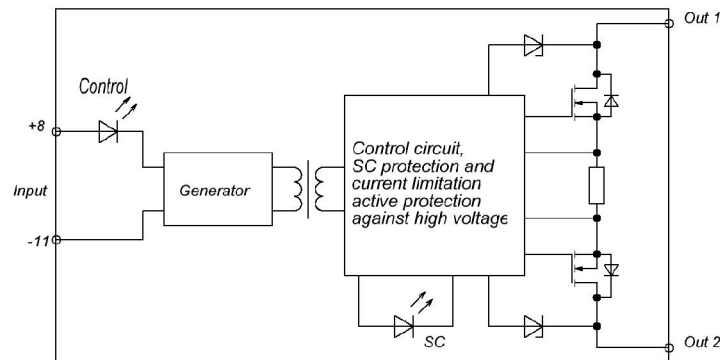

Figure 2.3 – Functional circuit MT16PT (figure 6.3)

Where D – module; PE – protection element.

In the all modules of 6 and 12 classes instead of MOSFET-transistors are installed IGBT-transistors with similar switching circuit (drain-source corresponds to collector-emitter).

Modules MT16PTA and MT16PTB have the inbuilt protections against overvoltage and overcurrent. The protection against overvoltage presented by Zener diode installed in parallel with collector-gate circuit (drain-source); when increasing the voltage (in collector-emitter circuit) set by the threshold Zener diode the power voltage opens up the transistor, thereby loading the circuit and decreasing voltage surge amplitude.

Current overload protection is represented with represented by a current collector resistor installed in the power circuit, with a comparison circuit and a reset circuit. When the current exceeds the set threshold during longer than 10 μ s the control circuit closes the transistor for 5...20 ms (it depends on the value of overcurrent), after that the transistor opens again and if overload wasn't eliminated then the protection cycle repeats.

3. BASIC PARAMETERS

Basic parameters and maximum permissible parameters of the modules at temperature 25 °C are shown in Tables 3.1 – 3.14.

Table 3.1 – Basic and maximum permissible control parameters of modules MT16

Parameter name, unit	Symbol	MT16 0.6, 1, 2, 2.5 – class	MT16 6, 12 – class	MT16PT 0.6, 1, 2, 2.5 – class	MT16PT 6, 12 – class
Input current of ver. «A» at $U_{IH} = 4$ V (max), mA	I_{IN}	7	7	50	50
Input current of ver. «A» at $U_{IH} = 10$ V (max), mA		15	15	70	70
Input current of ver. «B» at $U_{IH} = 10$ V (max), mA		15	15	60	60
Input current of ver. «B» at $U_{IH} = 30$ V (max), mA		20	20	80	80
Switch-on voltage of ver. «A», V	U_{IH}	4...10			
Switch-on voltage of ver. «B», V		10...30			
Switch-off voltage of ver. «A», V	U_{IL}	-3.5...0.8			
Switch-off voltage of ver. «B», V		-3.5...0.8			
On / off duration (max), μ s	$t_{on/off}$	50 / 50	50 / 50	100 / 100	100 / 100

Table 3.2 – Basic parameters of protections of modules MT16PT

Parameter name, unit	Symbol	Value	Notes
Current protection operation delay (max), μ s	$t_{d(SC)}$	10	
Blocking duration when operating of current protection (typ.), ms	$t_{B(SC)}$	20	
Current of protection operation against current overload (typ.), A	I_{SC}	For modules with max. current:	
		7.5	5
		15	10
		30	20
		45	30
Voltage of protection operation against overvoltage (typ.), V	U_{AC}	For modules with class:	
		48	0,6
		80	1
		145	2
		200	2,5
		480	6
		800	12

Table 3.3 – Basic and maximum permissible parameters of modules of 0,6 class – up to 80 A

Parameter name, unit	Symbol	Current, A				
		10	20	40	60	80
Drain-source voltage (max), V	V_{DSS}	+60				
Direct voltage of power circuit (max), V	V_{DC}	+35				
DC of power circuit (max), A	I_{DC}	+10	+20	+40	+60	+80
Pulse current of power circuit (max), A	I_P	+30	+60	+120	+180	+240
Drain-source resistance in open state (max), m Ω	$R_{DS(on)}$	120	56	24	6	12
Direct voltage fall on reverse diode (max), V	V_F	1.3				
Leakage current of power switch (max), μ A	I_{DSS}	100				
Junction temperature (max), $^{\circ}$ C	T_j	150				
Junction-base thermal resistance (max), $^{\circ}$ C/W	$R_{th(j-a)}$	1.4	0.8	0.5	0.35	0.25
Insulation strength, (DC), V	V_{ISOL}	1000				

Table 3.4 – Basic and maximum permissible parameters of modules of 0,6 class – up to 300 A

Parameter name, unit	Symbol	Current, A		
		120	200	300
Drain-source voltage (max), V	V_{DSS}	+60		
Direct voltage of power circuit (max), V	V_{DC}	+35		
DC of power circuit (max), A	I_{DC}	+120	+200	+300
Pulse current of power circuit (max), A	I_P	+360	+600	+900
Drain-source resistance in open state (max), m Ω	$R_{DS(on)}$	3	2	1.5
Direct voltage fall on reverse diode (max), V	V_F	1.3		
Leakage current of power switch (max), μ A	I_{DSS}	200		
Junction temperature (max), $^{\circ}$ C	T_j	150		
Junction-base thermal resistance (max), $^{\circ}$ C/W	$R_{th(j-a)}$	0.2	0.15	0.1
Insulation strength, (DC), V	V_{ISOL}	1000		

Table 3.5 – Basic and maximum permissible parameters of modules of 1 class – up to 80 A

Parameter name, unit	Symbol	Current, A					
		5	10	20	40	60	80
Drain-source voltage (max), V	V_{DSS}	+100					
Direct voltage of power circuit (max), V	V_{DC}	+60					
DC of power circuit (max), A	I_{DC}	+5	+10	+20	+40	+60	+80
Pulse current of power circuit (max), A	I_P	+15	+30	+60	+120	+180	+240
Drain-source resistance in open state (max), m Ω	$R_{DS(on)}$	400	180	88	46	35	23
Direct voltage fall on reverse diode (max), V	V_F	1.3					
Leakage current of power switch (max), μ A	I_{DSS}	50					
Junction temperature (max), $^{\circ}$ C	T_j	150					
Junction-base thermal resistance (max), $^{\circ}$ C/W	$R_{th(j-a)}$	1.6	1.1	0.7	0.5	0.28	0.23
Insulation strength, (DC), V	V_{ISOL}	1000					

Table 3.6 – Basic and maximum permissible parameters of modules of 1 class – up to 240 A

Parameter name, unit	Symbol	Current, A			
		120	160	200	240
Drain-source voltage (max), V	V_{DSS}	+100			
Direct voltage of power circuit (max), V	V_{DC}	+60			
DC of power circuit (max), A	I_{DC}	+120	+160	+200	+240
Pulse current of power circuit (max), A	I_P	+360	+480	+600	+720
Drain-source resistance in open state (max), m Ω	$R_{DS(on)}$	15	11.5	9.2	5.6
Direct voltage fall on reverse diode (max), V	V_F	1.3			
Leakage current of power switch (max), μ A	I_{DSS}	200			
Junction temperature (max), $^{\circ}$ C	T_j	150			
Junction-base thermal resistance (max), $^{\circ}$ C/W	$R_{th(j-a)}$	0.16	0.12	0.1	0.09
Insulation strength, (DC), V	V_{ISOL}	1000			

Table 3.7 – Basic and maximum permissible parameters of modules of 2 class – up to 80 A

Parameter name, unit	Symbol	Current, A					
		5	10	20	40	60	80
Drain-source voltage (max), V	V_{DSS}	+200					
Direct voltage of power circuit (max), V	V_{DC}	+130					
DC of power circuit (max), A	I_{DC}	+5	+10	+20	+40	+60	+80
Pulse current of power circuit (max), A	I_P	+15	+30	+60	+120	+180	+240
Drain-source resistance in open state (max), m Ω	$R_{DS(on)}$	600	300	164	44	46	22
Direct voltage fall on reverse diode (max), V	V_F	1.3					
Leakage current of power switch (max), μ A	I_{DSS}	50					
Junction temperature (max), $^{\circ}$ C	T_j	150					
Junction-base thermal resistance (max), $^{\circ}$ C/W	$R_{th(j-a)}$	1.0	0.6	0.46	0.31	0.21	0.16
Insulation strength, (DC), V	V_{ISOL}	1000					

Table 3.8 – Basic and maximum permissible parameters of modules of 2 class – up to 200 A

Parameter name, unit	Symbol	Current, A		
		120	160	200
Drain-source voltage (max), V	V_{DSS}	+200		
Direct voltage of power circuit (max), V	V_{DC}	+130		
DC of power circuit (max), A	I_{DC}	+120	+160	+200
Pulse current of power circuit (max), A	I_P	+360	+480	+600
Drain-source resistance in open state (max), m Ω	$R_{DS(on)}$	14.8	11	8.8
Direct voltage fall on reverse diode (max), V	V_F	1.3		
Leakage current of power switch (max), μ A	I_{DSS}	200		
Junction temperature (max), $^{\circ}$ C	T_j	150		
Junction-base thermal resistance (max), $^{\circ}$ C/W	$R_{th(j-a)}$	0.11	0.08	0.08
Insulation strength, (DC), V	V_{ISOL}	1000		

Table 3.9 – Basic and maximum permissible parameters of modules of 2,5 class – up to 40 A

Parameter name, unit	Symbol	Current, A				
		5	10	20	30	40
Drain-source voltage (max), V	V_{DSS}	+250				
Direct voltage of power circuit (max), V	V_{DC}	+170				
DC of power circuit (max), A	I_{DC}	+5	+10	+20	+30	+40
Pulse current of power circuit (max), A	I_P	+15	+30	+60	+90	+120
Drain-source resistance in open state (max), m Ω	$R_{DS(on)}$	560	280	150	84	60
Direct voltage fall on reverse diode (max), V	V_F	1.3				
Leakage current of power switch (max), μ A	I_{DSS}	50				
Junction temperature (max), $^{\circ}$ C	T_j	150				
Junction-base thermal resistance (max), $^{\circ}$ C/W	$R_{th(j-a)}$	0.5	0.41	0.36	0.31	0.26
Insulation strength, (DC), V	V_{ISOL}	1000				

Table 3.10 – Basic and maximum parameters of modules of 2,5 class – up to 120 A

Parameter name, unit	Symbol	Current, A		
		60	80	120
Drain-source voltage (max), V	V_{DSS}	+250		
Direct voltage of power circuit (max), V	V_{DC}	+170		
DC of power circuit (max), A	I_{DC}	+120	+160	+200
Pulse current of power circuit (max), A	I_P	+360	+480	+600
Drain-source resistance in open state (max), m Ω	$R_{DS(on)}$	42	30	20
Direct voltage fall on reverse diode (max), V	V_F	1.3		
Leakage current of power switch (max), μ A	I_{DSS}	200		
Junction temperature (max), $^{\circ}$ C	T_j	150		
Junction-base thermal resistance (max), $^{\circ}$ C/W	$R_{th(j-a)}$	0.16	0.13	0.09
Insulation strength, (DC), V	V_{ISOL}	1000		

Table 3.11 – Basic and maximum permissible parameters of modules of 6 class – up to 60 A

Parameter name, unit	Symbol	Current, A					
		5	10	20	30	40	60
Drain-source voltage (max), V	V_{CES}	+600					
Direct voltage of power circuit (max), V	V_{DC}	+350					
DC of power circuit (max), A	I_{DC}	+5	+10	+20	+30	+40	+60
Pulse current of power circuit (max), A	I_P	+15	+30	+60	+90	+120	+180
Drain-source resistance in open state (max), m Ω	$V_{CE(on)}$	3.0					
Direct voltage fall on reverse diode (max), V	V_F	2.5					
Leakage current of power switch (max), μ A	I_{CES}	500					
Junction temperature (max), $^{\circ}$ C	T_j	150					
Junction-base thermal resistance (max), $^{\circ}$ C/W	$R_{th(j-a)}$	1.6	1.4	0.76	0.7	0.6	0.52
Insulation strength, (DC), V	V_{ISOL}	4000					

Table 3.12 – Basic and maximum permissible parameters of modules of 6 class – up to 160 A

Parameter name, unit	Symbol	Current, A		
		80	120	160
Drain-source voltage (max), V	V_{CES}	+600		
Direct voltage of power circuit (max), V	V_{DC}	+350		
DC of power circuit (max), A	I_{DC}	+80	+120	+160
Pulse current of power circuit (max), A	I_P	+240	+360	+480
Drain-source resistance in open state (max), m Ω	$V_{CE(on)}$	3.0		
Direct voltage fall on reverse diode (max), V	V_F	2.5		
Leakage current of power switch (max), μ A	I_{CES}	500		
Junction temperature (max), $^{\circ}$ C	T_j	150		
Junction-base thermal resistance (max), $^{\circ}$ C/W	$R_{th(j-a)}$	0.33	0.26	0.18
Insulation strength, (DC), V	V_{ISOL}	4000		

Table 3.13 – Basic and maximum permissible parameters of modules of 12 class – up to 40 A

Parameter name, unit	Symbol	Current, A				
		5	10	20	30	40
Drain-source voltage (max), V	V_{CES}	+1200				
Direct voltage of power circuit (max), V	V_{DC}	+650				
DC of power circuit (max), A	I_{DC}	+5	+10	+20	+30	+40
Pulse current of power circuit (max), A	I_P	+15	+30	+60	+90	+120
Drain-source resistance in open state (max), m Ω	$V_{CE(on)}$	3.0				
Direct voltage fall on reverse diode (max), V	V_F	2.5				
Leakage current of power switch (max), μ A	I_{CES}	500				
Junction temperature (max), $^{\circ}$ C	T_j	150				
Junction-base thermal resistance (max), $^{\circ}$ C/W	$R_{th(j-a)}$	2.3	1.4	0.8	0.6	0.52
Insulation strength, (DC), V	V_{ISOL}	4000				

Table 3.14 – Basic and maximum permissible parameters of modules of 12 class – up to 120 A

Parameter name, unit	Symbol	Current, A		
		60	80	120
Drain-source voltage (max), V	V_{CES}	+1200		
Direct voltage of power circuit (max), V	V_{DC}	+650		
DC of power circuit (max), A	I_{DC}	+60	+80	+120
Pulse current of power circuit (max), A	I_P	+180	+240	+360
Drain-source resistance in open state (max), m Ω	$V_{CE(on)}$	3.0		
Direct voltage fall on reverse diode (max), V	V_F	2.5		
Leakage current of power switch (max), μ A	I_{CES}	500		
Junction temperature (max), $^{\circ}$ C	T_j	150		
Junction-base thermal resistance (max), $^{\circ}$ C/W	$R_{th(j-a)}$	0.36	0.26	0.18
Insulation strength, (DC), V	V_{ISOL}	4000		

4. INSTRUCTIONS FOR USE

General requirements

It is recommended to operate the module at operating value of the average current not more than 80% from specified one in the name of the module and the junction temperature not more than (70÷80)% from the maximum one.

It is not allowed to operate the module in modes at simultaneous influence of two or more maximum permissible values.

In the electric circuit of equipment with using of the modules should be provided the fast-speed protection against prohibitive overloads, SCs and commutating overloads.

Module mounting

The module is mounted in the equipment to cooler (chassis, application housing, metal plates, etc.) in any orientation with screws M4 with torque (5 ± 0.5) N·m, with obligatory installation of flat and spring washers. The module should be located in such a way to protect it against additional heat from neighbor elements. The planes of cooler ribs should be oriented in the direction of air flow.

The contact area of the cooler should have roughness not more than $2.5\ \mu\text{m}$ and flatness tolerance – not more than $30\ \mu\text{m}$. Cooler surface should not have any rough edges, honeycombs. There should not be extraneous particles between the module and cooler. To improve the heat balance the module installation to mounting area or cooler should be carried out by instrumentality of heat conducting pastes or having similar heat conducting properties.

When mounting, you should provide uniform pressure of module housing to cooler. For this purpose you should tighten all screws uniform in 2 – 4 steps by turns: first, located on one diagonal, then on the other one. When dismantling the module the screw tightening should be done in the reverse order.

Not earlier than in 3 hours after mounting the screws should be rotated to the end, keeping the prescribed torque, because the part of heat conducting paste under pressure will outflow and the fastening can fail.

You can mount the several modules without additional insulating spacer to one cooler, on condition that voltage between outputs of different modules will not exceed the minimum value of isolation breakdown voltage of each of them or when cooler is grounded.

Connection to module

Electric wires and cables will be connected to power contacts of the module by means of screws M6 or M5 with torque (4 ± 0.5) N·m or by means of bolts M8 or M10 with torque (5 ± 0.5) N·m and the washers that are supplied in the package.

Power wires should be connected by means of connectors with corrosion-inhibiting cover, which are purified of foreign layers. When the screws (bolts) are tightened it is recommended to fasten the connection with paint. It is recommended to tighten screws (bolts) repeatedly in 8 days and in 6 weeks after the start of operating. Afterwards tightening should be controlled at least once a half year.

The controlling module outputs are intended for mounting in equipment by means of soldering or split connectors. Permissible number of module outputs' re-soldering during electronic (assembly) edit is three. Outputs soldering should be performed at temperature not higher than (235 ± 5) °C. Soldering duration is not longer than 3 sec.

When mounting and operating it is necessary to make protection measures against static electricity impact and overvoltage in gate circuit; on mounting personnel should use a ground band and grounded low-voltage soldering irons with transformer supply.

Operation requirements

The module should be used under mechanical loads in accordance with Table 4.1.

Table 4.1 – Mechanical loads impact

External exposure factor	External exposure factor value
Sinusoidal vibration: - acceleration, m/s^2 (g); - frequency, Hz	150 (15) 0.5 - 100
Multiple-acting mechanic shock: - peak shock acceleration, m/s^2 (g); - shock acceleration duration, ms	40 (4) 50
Linear acceleration, m/s^2 (g)	5000 (500)

The module should be used under climatic loads in accordance with Table 4.2.

Table 4.2 – Climatic loads impact

Climatic factor	Climatic factor value
Reduced ambient temperature: - operating, °C; - maximum, °C	- 40 - 45
High ambient temperature: - operating, °C; - maximum, °C	+ 85 + 100
Relative humidity at temperature 35 °C without moisture condensation, %, max	98

Safety requirements

1. Working with the module should only be performed by qualified personnel.
2. Do not touch the power terminals of the module when applying a voltage.
3. Do not connect or disconnect wires and connectors while the power to the circuit module is applying a voltage.
4. Do not touch the module radiator, if it is not grounded in and is applying a voltage on it.
5. Do not touch the cooler and the module housing during its operation, since their temperature can be very high.
6. Immediately turn off the power supply of the module if it discharges smoke, odor or abnormal noises, check if the module correctly connected.
7. It is not allowed to penetrate water and other liquids to the module.

5. RELIABILITY REQUIREMENTS

The manufacturer guarantees the quality of the module all the requirements of the user's manual passport if the consumer observes terms and conditions of storage, installation and operation, as well as guidance on the application specified in the user's manual.

Operating warranty is two years from the acceptance date, in case of requalification – from the date of the requalification.

Reliability probability of the module for 25000 hours must be at least 0.95.

Gamma percentage life (T_γ) of module at $\gamma = 90\%$ in typical operation conditions should not be less than 50 000 hours within lifetime.

Gamma-percent service life of the modules, subject to cumulative operating time is not more than gamma-percent life, not less than 10 years, at $\gamma = 90\%$.

Gamma-percent storageability time of the modules, at $\gamma = 90\%$ and storing – 10 years.

6. OVERALL AND CONNECTING DIMENSIONS

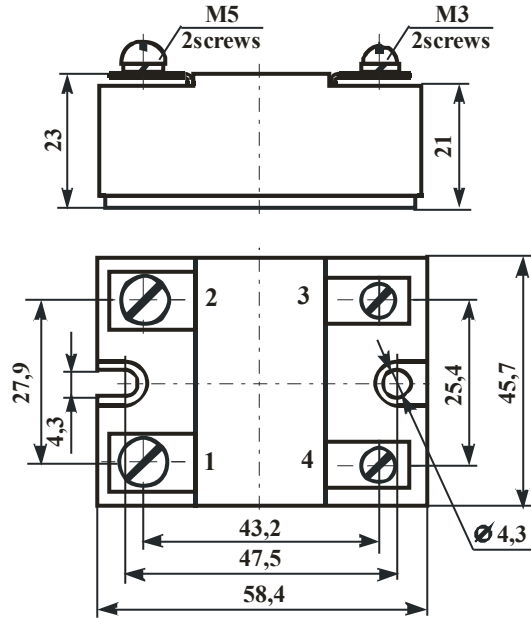

Figure 6.1 – Overall drawing of modules MT16 with maximum current up to 40 A

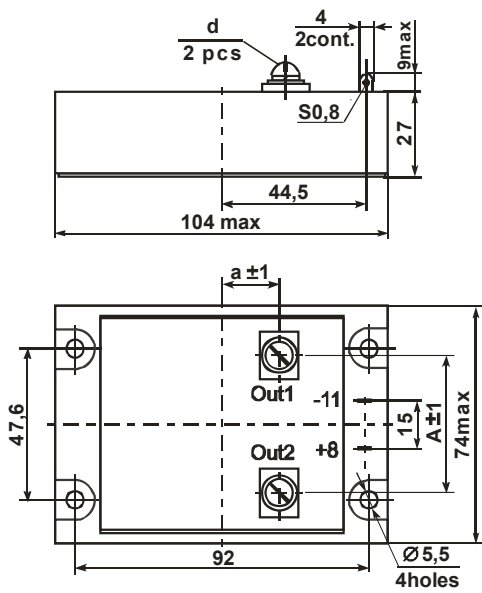

Figure 6.2 – Overall drawing of modules MT16 with maximum current up to 300 A

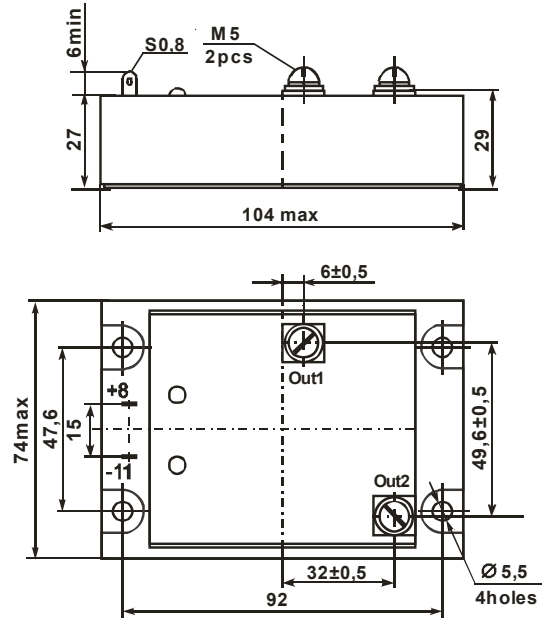

Figure 6.3 – Overall drawing of modules MT16PT

Current, A	d	a, mm	A, mm
≤160	Screw M6	18	43
200, 240	Bolt M8	21	45
300	Bolt M10	21	41

Precious metals are not contained.