



ELECTRUM AV

www.electrum-av.com

01.01.2013
Modules IGBT M1.doc

**IGBT TRANSISTOR MODULES
IN M1 DESIGN VERSION**

USER'S MANUAL



5 Naugorskoe highway, Orel, 302020, Russia Tel. +7(4862) 44-03-44, Fax +7(4862) 47-02-12

E-mail: mail@electrum-av.com

CONTENTS

1. APPLICATION AND PRODUCED MODULES		3
2. GENERAL DESCRIPTION		7
3. BASIC PARAMETERS		9
4. INSTRUCTIONS FOR USE		12
5. RELIABILITY REQUIREMENTS		13
6. OVERALL AND CONNECTING DIMENSIONS		14

This document is a user's manual with a description of characteristics of this product for which are warranted. All the products in the production process pass a complete set of electrical tests, which are performed twice, once before encapsulation, and then again after it. Tests carried out by "Electrum AV" are exhaustive and include 100% control at the final testing.

Any such warranty is provided only in accordance with the terms of the supply agreement (supply contract or other documents in accordance with applicable law). The information presented in this document does not provide warranties and liability of "Electrum AV" by the use of such information and the suitability of products for your equipment. The data contained in this document are intended exclusively for technically trained staff. You and your technical expert will have to evaluate the suitability of the product for the application and the completeness of the product data, in connection with this application.

Any products of "Electrum AV" are not permitted for the use in devices and life support systems and special equipment without the prior written consent of "Electrum AV".

If you need information about the product, which is not shown in this user's manual or which concerns the specific application of our product, please contact the sales office to the manager who is responsible for your enterprise.

Engineers "Electrum AV" have a lot of experience in the design, manufacture and application of powerful force devices and smart drivers and has already implemented a large number of individual decisions. If you need power modules and drivers that are not included in the package, as well as products with differences from the standard devices in specifications or design, please contact to our managers and specialists who will offer you best solution for your application. "Electrum AV" reserves the right to make changes without notice in this document to improve the reliability, functionality and design improvement.

1. APPLICATION AND PRODUCED MODULES

IGBT-modules in design version «M1» represents assemblies of IGBT-transistors and FRD-diodes for power loads commutation being a part of converters with maximum peak voltage up to 1700V and DC up to 600A. IGBT-modules are represented with the following versions:

M9.1 – diode and transistor that series-connected (common cathode-collector). Module is produced with number of maximum DC 150,200,300 A with peak voltage 1200 V.

M10 – lower switch. Module is produced with number of maximum DC 350,450,600 A with peak voltage 600 V, in current number of 150,200,300,400 A with peak voltage 1200 V, in current number of 150,200,300 A with peak voltage 1700 V.

M11 – upper switch. Module is produced with number of maximum DC 350,450,600 A with peak voltage 600 B, in current number of 150,200,300,400 A with peak voltage 1200 V, in current number of 150,200,300 A with peak voltage 1700 V.

M12 – two parallel connected IGBT-transistors (half-bridge). Module is produced with number of maximum DC 350,450,600 A with peak voltage 600 V, in current number of 150,200,300,400 A c with peak voltage 1200 V, in current number of 150,200,300 A with peak voltage 1700 V.

M12.1 – two parallel connected IGBT-transistors (common emitter). Module is produced with number of maximum DC 300,350,450,600 A with peak voltage 600 V, in current number of 150, 200,300,400 A with peak voltage 1200 V, in current number of 50,200,300 A with peak voltage 1700 V.

M13A – three half bridges. Module is produced with number of maximum DC 50,75,100,150 A with peak voltage 600 V, in current number of 50,75,100 A with peak voltage 1200 V, current 50 A with peak voltage 1700 V.

M13A4 – H-bridge и chopper. Module is produced with number of maximum DC 100 A with peak voltage 600 V, current 50 A with peak voltage 1200 V.

M13A5 – three level inverter. Module is produced with number of maximum DC 150,200 A with peak voltage 600 V, current 200 A with peak voltage 1200 V, current 100 A with peak voltage 1700 V.

M13B – H-bridge. Module is produced with number of maximum DC 150,200 A with peak voltage 1200 V, in current number of 100,150 A with peak voltage 1700 V.

M13B1 – skew bridge. Module is produced with number of maximum DC 150,200 A with peak voltage 1200 V, in current number of 100,150 A with peak voltage 1700 V.

In dependence from the version the modules are produced regarding to the design in Table 1.1. Modules are produced only in versions where at cross of class line and current column is indicated appropriate to present version overall dimension drawing.

Table 1.1 – Produced IGBT-modules and appropriate overall drawings

Type	Class	Current, A									
		50	75	100	150	200	300	350	400	450	600
M9.1	6										
	12				6.1	6.1	6.1				
	17				6.1	6.1	6.1				
M10	6							6.2		6.2	6.2
	12				6.2	6.2	6.2		6.2		
	17				6.2	6.2	6.2				
M11	6							6.3		6.3	6.3
	12				6.3	6.3	6.3		6.3		
	17				6.3	6.3	6.3				
M12	6							6.4		6.4	6.4
	12				6.4	6.4	6.4		6.4		
	17				6.4	6.4	6.4				
M12.1	6							6.5		6.5	6.5
	12				6.5	6.5	6.5		6.5		
	17				6.5	6.5	6.5				
M13A	6	6.6	6.6	6.6	6.6						
	12	6.6	6.6	6.6							
	17	6.6									
M13A4	6			6.7							
	12	6.7									
	17										
M13A5	6				6.8	6.8					
	12					6.8					
	17			6.8							
M13B	6										
	12				6.9	6.9					
	17			6.9	6.9						
M13B1	6										
	12				6.10	6.10					
	17			6.10	6.10						

At Figure 1.1 is provided explanation of the modules names.

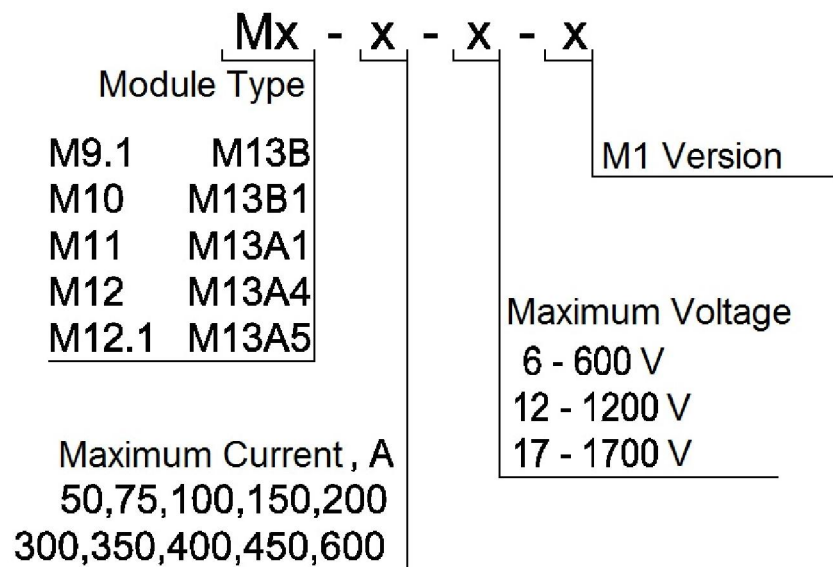

Figure 1.1 – Module names explanation

For example, module M12-200-12-M1: half-bridge with maximum permissible voltage collector-emitter 1200V, maximum permissible DC 200A of version M1.

Table 1.2 – 6 class modules concordance

Class, V	Current, A	Microsemi	Electrum AV, CJSC
Dual common source			
600	300	APTGT300DU60G	M12.1-300-6-M1
600	350	APTGF350DU60G	M12.1-350-6-M1
600	450	APTGT450DU60G	M12.1-450-6-M1
600	600	APTGT600DU60G	M12.1-600-6-M1
Triple phase leg			
600	50	APTGT50TA60PG	M13A-50-6-M1
600	75	APTGT75TA60PG	M13A-75-6-M1
600	100	APTGT100TA60PG	M13A-100-6-M1
600	150	APTGT150TA60PG	M13A-150-6-M1
Lower switch			
600	350	APTGF350DA60G	M10-350-6-M1
600	450	APTGT450DA60G	M10-450-6-M1
600	600	APTGT600DA60G	M10-600-6-M1
Upper switch			
600	350	APTGF350SK60G	M11-350-6-M1
600	450	APTGT450SK60G	M11-450-6-M1
600	600	APTGT600SK60G	M11-600-6-M1
Half-bridge			
600	350	APTGF350A60G	M12-350-6-M1
600	450	APTGT450A60G	M12-450-6-M1
600	600	APTGT600A60G	M12-600-6-M1
PFC + Full bridge			
600	100	APTGV100H60BTPG	M13A4-100-6-M1
Three-level inverter			
600	150	APTGT150TL60G	M13A5-150-6-M1
600	200	APTGT200TL60G	M13A5-200-6-M1
600	300	APTGT300TL60G	M13A5-300-6-M1

Table 1.3 – 12 class modules concordance

Class, V	Current, A	Microsemi	Electrum AV, CJSC
Dual common source			
1200	150	APTGT150DU120G	M12.1-150-12-M1
1200	200	APTGT200DU120G	M12.1-200-12-M1
1200	300	APTGT300DU120G	M12.1-300-12-M1
1200	400	APTGT400DU120G	M12.1-400-12-M1
Triple phase leg			
1200	50	APTGF50TA120PG	M13A.1-50-12-M1
1200	75	APTGT75TA120PG	M13A.1-75-12-M1
1200	100	APTGT100TA120TPG	M13A.1-100-12-M1
Low switch			
1200	150	APTGT150DA120G	M10-150-12-M1
1200	200	APTGT200DA120G	M10-200-12-M1
1200	300	APTGF300DA120G	M10-300-12-M1
1200	400	APTGT400DA120G	M10-400-12-M1
Upper switch			
1200	150	APTGT150SK120G	M11-150-12-M1
1200	200	APTGT200SK120G	M11-200-12-M1
1200	300	APTGF350SK120G	M11-300-12-M1
1200	400	APTGT400SK120G	M11-400-12-M1
Half-bridge			
1200	150	APTGT150A120G	M12-150-12-M1
1200	200	APTGT200A120G	M12-200-12-M1
1200	300	APTGF300A120G	M12-300-12-M1
1200	400	APTGT400A120G	M12-400-12-M1
Full-bridge			
1200	150	APTGT100H120G	M13 B-150-12-M1
1200	200	APTGT200H120G	M13 B-200-12-M1

Table 1.3 continuation

Asymmetrical-bridge			
1200	150	APTGT100DH120G	M13 B1-150-12-M1
1200	200	APTGT200DH120G	M13 B1-200-12-M1
PFC + Full bridge			
1200	50	APTGV50H120BTPG	M13A4-50-12-M1
Three level inverter			
1200	240	APTGL240TL120G	M13A5-240-12-M1

Table 1.4 – 17 class modules concordance

Class, V	Current, A	Microsemi	Electrum AV, CJSC
Dual common source			
1700	150	APTGT150DU170G	M12.1-150-17-M1
1700	200	APTGT225DU170G	M12.1-200-17-M1
1700	300	APTGT300DU170G	M12.1-300-17-M1
Triple phase leg			
1700	50	APTGT50TA170PG	M13A.1-50-17-M1
Lower switch			
1700	150	APTGT150DA170G	M10-150-17-M1
1700	200	APTGT225DA170G	M10-200-17-M1
1700	300	APTGT300DA170G	M10-300-17-M1
Upper switch			
1700	150	APTGT150SK170G	M11-150-17-M1
1700	200	APTGT225SK170G	M11-200-17-M1
1700	300	APTGT300SK170G	M11-300-17-M1
Half-bridge			
1700	150	APTGT150A170G	M12-150-17-M1
1700	200	APTGT225A170G	M12-200-17-M1
1700	300	APTGT300A170G	M12-300-17-M1
Full-bridge			
1700	100	APTGT100H170G	M13 B-100-17-M1
1700	150	APTGT150H170G	M13 B-150-17-M1
Asymmetrical bridge			
1700	100	APTGT100DH170G	M13 B1-100-17-M1
1700	150	APTGT150DH170G	M13 B1-150-17-M1
Three-level inverter			
1700	100	APTGT100TL170G	M13A5-100-17-M1

2. GENERAL DESCRIPTION

In dependence on the module type the electrical circuits are different; at Figures 2.1 – 2.10 are represented possible circuits variants of IGBT-modules.

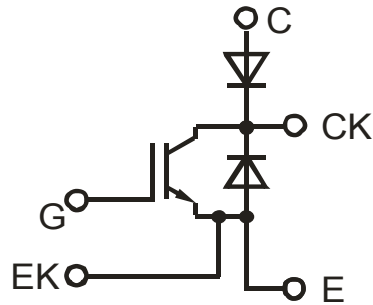

Figure 2.1 – M9.1 Modules electric circuit

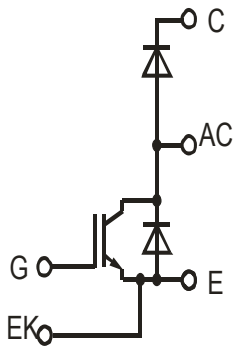

Figure 2.2 – M10 Modules electric circuit

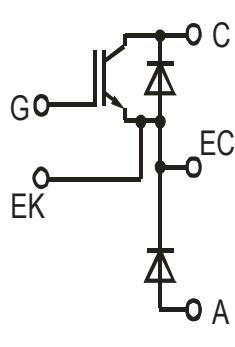

Figure 2.3 – M11 Modules electric circuit

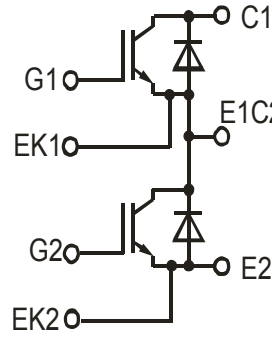

Figure 2.4 – M12 Modules electric circuit

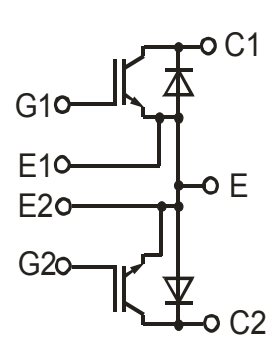

Figure 2.5 – M12.1 Modules electric circuit

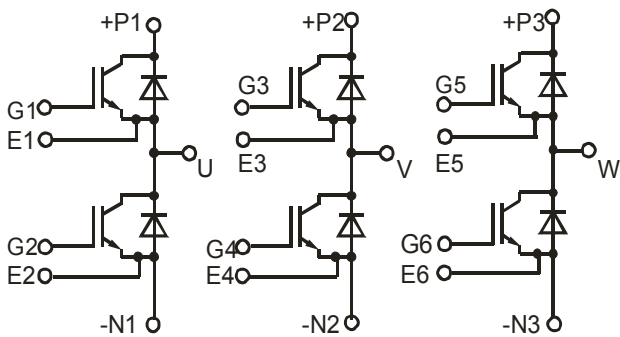

Figure 2.6 – M13A1 Modules electric circuit

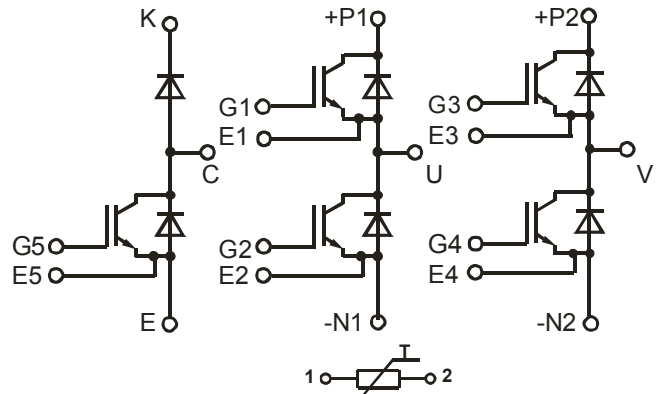

Figure 2.7 – M13A4 Modules electric circuit

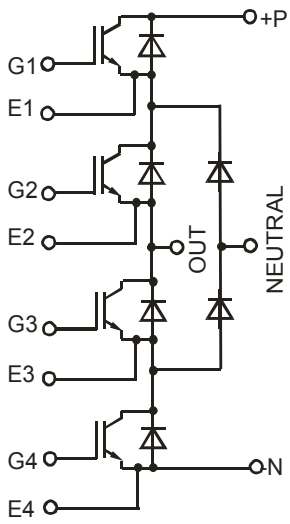

Figure 2.8 – Modules electric circuitM13A5

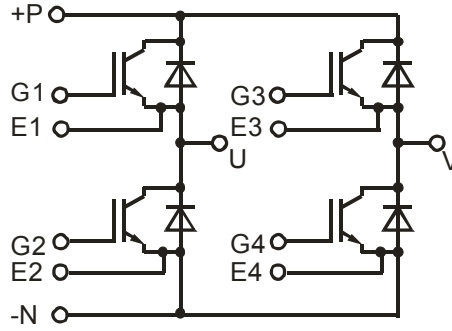

Figure 2.9 – Modules electric circuitM13 B

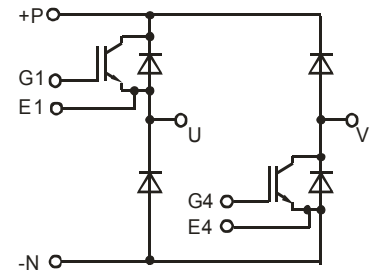

Figure 2.10 – Modules electric circuitM13 B1

Attention! When transporting the gate and emitter must be short-circuited!

3. BASIC PARAMETERS

Basic electrical parameters and maximum permissible modules' parameters at temperature 25⁰C are shown in Tables 3.1 - 3.4

Table 3.1 – Basic and maximum permissible parameters of modules of 6-th class with maximum DC up to 150A.

Parameter name, Unit	Symbol	Module maximum DC, A			
		50	75	100	150
Basic characteristics					
Collector-emitter breakdown voltage (min), V	$V_{(BR)CES}$	600			
Power circuit direct voltage (max), V	V_{DC}	350			
Power circuit DC (max), A	I_{DC}	50	75	100	150
Junction-transistor housing thermal resistance, °C/W	$R_{T(j-c)VT}$	0.4	0.35	0.3	0.2
Junction-diode housing thermal resistance, °C/W	$R_{T(j-c)VD}$	0.7	0.65	0.6	0.4
Power dissipation (max), W	P_D	300	360	420	625
Isolation strength (DC), V	V_{ISOL}	4000			
Static characteristics					
Gate-emitter threshold voltage, V	$V_{GE(th)}$	4.5...6.5	4.5...6.5	4.5...6.5	4.5...6.5
Gate leakage current (max), nA	I_{GES}	+500	+500	+500	+500
Collector-emitter saturation voltage (typical), V	$V_{CE(on)}$	1.7	1.7	1.7	1.7
Collector-emitter saturation voltage (max), V	$V_{CE(on)}$	2.2	2.2	2.2	2.2
Collector leakage current (max), µA	I_{CES}	100	100	100	100
Dynamic characteristics					
Input capacitance (typical), pF	C_{ies}	4000	4000	4500	6000
Output capacitance (typical), pF	C_{oes}	250	250	300	450
Transfer capacitance (typical), pF	C_{res}	200	200	220	300
Switch-on delay time (max), ns	$t_{d(on)}$	150	150	150	200
Rise time (max), ns	t_r	80	80	80	200
Switch-off delay time (max), ns	$t_{d(off)}$	700	700	700	700
Fall time (max), ns	t_f	150	150	150	150
Switch-on loss energy (max), mJ	E_{ON}	5	5	5.5	18
Switch-off loss energy (max), mJ	E_{OFF}	7	7	7.6	24
Common gate charge (typical), nC	Q_G	400	500	600	800
Reverse diode characteristics					
Direct voltage fall (typical), V	V_F	2.1	2.1	2.1	2.1
Diode direct current (max), A	I_F	50	75	100	150
Diode pulse current at $t_{pul} = 1$ ms (max), A	I_{FM}	150	225	300	450
Reverse recovery current (typical), A	I_{RR}	50	50	75	125
Recovery time (typical), ns	t_{RR}	200	200	200	250
Maximum permissible modes					
Collector-emitter voltage (max), V	V_{CES}	600			
Gate-emitter voltage (max), V	V_{GE}	+20			
Collector DC at T = 25 °C (max), A	I_C	70	100	120	175
Collector DC at T = 100 °C (max), A	I_C	50	75	100	150
Collector pulse current at $t_{pul} = 1$ ms (max), A	I_{CM}	150	225	300	450
Junction temperature (max), °C	T_j	150			

Table 3.2 – Basic and maximum permissible parameters of modules of 6-th class with maximum DC up to 600A.

Parameter name, Unit	Symbol	Module maximum DC, A				
		200	300	350	450	600
Basic characteristics						
Collector-emitter breakdown voltage (min), V	$V_{(BR)CES}$	600				
Power circuit direct voltage (max), V	V_{DC}	350				
Power circuit DC (max), A	I_{DC}	200	300	350	450	600
Junction-transistor housing thermal resistance, °C/W	$R_{T(j-c)VT}$	0.15	0.15	0.1	0.06	0.06
Junction-diode housing thermal resistance, °C/W	$R_{T(j-c)VD}$	0.25	0.25	0.2	0.12	0.12
Power dissipation (max), W	P_D	830	840	1250	2100	2100
Isolation strength (DC), V	V_{ISOL}	4000				
Static characteristics						
Gate-emitter threshold voltage, V	$V_{GE(th)}$	4.5...6.5	4.5...6.5	4.5...6.5	4.5...6.5	4.5...6.5
Gate leakage current (max), nA	I_{GES}	± 500	± 500	± 500	± 500	± 500
Collector-emitter saturation voltage (typical), V	$V_{CE(on)}$	1.7	1.7	1.7	1.7	1.7
Collector-emitter saturation voltage (max), V	$V_{CE(on)}$	2.2	2.2	2.4	2.4	2.4
Collector leakage current (max), μA	I_{CES}	100	100	300	300	300
Dynamic characteristics						
Input capacitance (typical), pF	C_{ies}	15000	18000	25000	42000	42000
Output capacitance (typical), pF	C_{oes}	1500	1500	2000	4000	4000
Transfer capacitance (typical), pF	C_{res}	1000	1000	1500	3000	3000
Switch-on delay time (max), ns	$t_{d(on)}$	300	150	150	250	250
Rise time (max), ns	t_r	150	80	80	120	120
Switch-off delay time (max), ns	$t_{d(off)}$	700	700	700	900	900
Fall time (max), ns	t_f	150	150	150	150	150
Switch-on loss energy (max), mJ	E_{ON}	20	25	30	70	70
Switch-off loss energy (max), mJ	E_{OFF}	30	35	60	150	150
Common gate charge (typical), nC	Q_G	1500	1800	1800	3000	3000
Reverse diode characteristics						
Direct voltage fall (typical), V	V_F	2.1	2.1	2.1	2.1	2.1
Diode direct current (max), A	I_F	200	300	400	600	600
Diode pulse current at $t_{pul} = 1$ ms (max), A	I_{FM}	600	900	1200	1800	1800
Reverse recovery current (typical), A	I_{RR}	250	350	450	700	700
Recovery time (typical), ns	t_{RR}	300	250	300	300	300
Maximum permissible modes						
Collector-emitter voltage (max), V	V_{CES}	600				
Gate-emitter voltage (max), V	V_{GE}	± 20				
Collector DC at $T = 25$ °C (max), A	I_C	240	350	500	700	700
Collector DC at $T = 100$ °C (max), A	I_C	200	300	400	600	600
Collector pulse current at $t_{pul} = 1$ ms (max), A	I_{CM}	600	900	1200	1800	1800
Junction temperature (max), °C	T_j	150				

Table 3.3 – Basic and maximum permissible parameters of modules of 12 class

Parameter name, Unit	Symbol	Module maximum DC, A						
		50	75	100	150	200	300	400
Basic characteristics								
Collector-emitter breakdown voltage (min), V	$V_{(BR)CES}$	600						
Power circuit direct voltage (max), V	V_{DC}	350						
Power circuit DC (max), A	I_{DC}	50	75	90	150	200	300	400
Junction-transistor housing thermal resistance, °C/W	$R_{T(j-c)VT}$	0.4	0.35	0.3	0.2	0.15	0.15	0.1
Junction-diode housing thermal resistance, °C/W	$R_{T(j-c)VD}$	0.7	0.65	0.6	0.4	0.25	0.25	0.2
Power dissipation (max), W	P_D	300	360	420	625	830	840	1250
Isolation strength (DC), V	V_{ISOL}	4000						

Table 3.3 continuation

Static characteristics								
Gate-emitter threshold voltage, V	$V_{GE(th)}$	4.5...6.5						
Gate leakage current (max), nA	I_{GES}	+500	+500	+500	+500	+500	+500	+500
Collector-emitter saturation voltage (typical), V	$V_{CE(on)}$	1.7	1.7	1.7	1.7	1.7	1.7	1.7
Collector-emitter saturation voltage (max), V	$V_{CE(on)}$	2.2	2.2	2.2	2.2	2.2	2.2	2.4
Collector leakage current (max), μ A	I_{CES}	100	100	100	100	100	100	300
Dynamic characteristics								
Input capacitance (typical), pF	C_{ies}	4000	4000	4500	6000	15000	18000	25000
Output capacitance (typical), pF	C_{oes}	250	250	300	450	1500	1500	2000
Transfer capacitance (typical), pF	C_{res}	200	200	220	300	1000	1000	1500
Switch-on delay time (max), ns	$t_{d(on)}$	150	150	150	200	300	150	150
Rise time (max), ns	t_r	80	80	80	200	150	80	80
Switch-off delay time (max), ns	$t_{d(off)}$	700	700	700	700	700	700	700
Fall time (max), ns	t_f	150	150	150	150	150	150	150
Switch-on loss energy (max), mJ	E_{ON}	5	5	5.5	18	20	25	30
Switch-off loss energy (max), mJ	E_{OFF}	7	7	7.6	24	30	35	60
Common gate charge (typical), nC	Q_G	400	500	600	800	1500	1800	1800
Reverse diode characteristics								
Direct voltage fall (typical), V	V_F	2.1	2.1	2.1	2.1	2.1	2.1	2.1
Diode direct current (max), A	I_F	50	75	100	150	200	300	400
Diode pulse current at $t_{pul} = 1$ ms (max), A	I_{FM}	150	225	300	450	600	900	1200
Reverse recovery current (typical), A	I_{RR}	50	50	75	125	250	350	450
Recovery time (typical), ns	t_{RR}	200	200	200	250	300	250	300
Maximum permissible modes								
Collector-emitter voltage (max), V	V_{CES}	600						
Gate-emitter voltage (max), V	V_{GE}	+20						
Collector DC at $T = 25$ °C (max), A	I_C	70	100	120	175	240	350	500
Collector DC at $T = 100$ °C (max), A	I_C	50	75	100	150	200	300	400
Collector pulse current at $t_{pul} = 1$ ms (max), A	I_{CM}	150	225	300	450	600	900	1200
Junction temperature (max), °C	T_j	150						

Table 3.4 – Basic and maximum permissible parameters of modules of 17 class

Parameter name, Unit	Symbol	Module maximum DC, A				
		50	100	150	200	300
Basic characteristics						
Collector-emitter breakdown voltage (min), V	$V_{(BR)CES}$	1700				
Power circuit direct voltage (max), V	V_{DC}	950				
Power circuit DC (max), A	I_{DC}	50	100	150	200	300
Junction-transistor housing thermal resistance, °C/W	$R_{T(j-e)VT}$	0.6	0.3	0.2	0.15	0.1
Junction-diode housing thermal resistance, °C/W	$R_{T(j-e)VD}$	1.0	0.5	0.33	0.25	0.17
Power dissipation (max), W	P_D	210	420	630	830	1250
Isolation strength (DC), V	V_{ISOL}	5000				
Static characteristics						
Gate-emitter threshold voltage, V	$V_{GE(th)}$	2.5...6	2.5...6	2.5...6	2.5...6	2.5...6
Gate leakage current (max), nA	I_{GES}	+500	+500	+500	+500	+500
Collector-emitter saturation voltage (typical), V	$V_{CE(on)}$	2.7	2.7	2.7	2.7	2.7
Collector-emitter saturation voltage (max), V	$V_{CE(on)}$	3.2	3.2	3.2	3.2	3.2
Collector leakage current (max), μ A	I_{CES}	50	50	50	50	50
Dynamic characteristics						
Input capacitance (typical), pF	C_{ies}	3500	7000	10500	14000	21000
Output capacitance (typical), pF	C_{oes}	300	600	900	1200	1800
Transfer capacitance (typical), pF	C_{res}	200	400	600	800	1200
Switch-on delay time (max), ns	$t_{d(on)}$	170	170	170	170	170
Rise time (max), ns	t_r	50	50	50	50	50
Switch-off delay time (max), ns	$t_{d(off)}$	200	200	200	200	200
Fall time (max), ns	t_f	80	80	80	80	80
Switch-on loss energy (max), mJ	E_{ON}	16	32	48	64	96
Switch-off loss energy (max), mJ	E_{OFF}	10	20	30	40	60
Common gate charge (typical), nC	Q_G	375	750	1125	1500	2250

Table 3.4 continuation

Reverse diode characteristics						
Direct voltage fall (typical), V	V_F	2.2	2.2	2.2	2.2	2.2
Diode direct current (max), A	I_F	100	100	200	200	300
Diode pulse current at $t_{pul} = 1$ ms (max), A	I_{FM}	300	300	600	600	900
Reverse recovery current (typical), A	I_{RR}	50	50	100	100	200
Recovery time (typical), ns	t_{RR}	300	300	300	300	300
Maximum permissible modes						
Collector-emitter voltage (max), V	V_{CES}	1700				
Gate-emitter voltage (max), V	V_{GE}	±20				
Collector DC at $T = 25$ °C (max), A	I_C	55	110	175	220	330
Collector DC at $T = 100$ °C (max), A	I_C	50	100	150	200	300
Collector pulse current at $t_{pul} = 1$ ms (max), A	I_{CM}	150	300	450	600	900
Junction temperature (max), °C	T_j	150				

4. INSTRUCTIONS FOR USE

General requirements

It is recommended to operate the module at operating value of average current not more than 80% from the mentioned in the name of the module and junction temperature not more than (70÷80)% from maximum one.

It is not allowed operating the modules in modes at simultaneous impacting two or more maximum permissible parameters' values.

In the electrical circuit of the equipment with use of the modules should be provided a fast-recovery protection against overloads, SCs and commutating overloads.

Module mounting

The module is mounted in the equipment to cooler (chassis, application housing, metal plates, etc.) in any orientation with screws M5 or M6 with torque (5±0.5) N·m, with obligatory installation of flat and spring washers. The module should be located in such a way to protect it against additional heat from neighboring elements. The planes of cooler ribs should be oriented in the direction of air flow.

The contact area of the cooler should have roughness not more than 2.5 µm and flatness tolerance– not more than 30 µm. Cooler surface should not have any rough edges, honeycombs. There should not be extraneous particles between the module and cooler. To improve the heat balance the module installation to mounting area or cooler should be carried out by instrumentality of heat conducting pastes or having similar heat conducting properties.

When mounting, you should provide uniform pressure of module housing to cooler. For this purpose you should tighten all screws uniform in 2 – 4 motions by turns: first, located on one diagonal, then on the other one. Disassembling the module the screw tightening should be done the reverse order. Not earlier than in 3 hours after mounting the screws should be rotated to the end, keeping the prescribed torque, because the part of heat conducting paste under pressure will outflow and the fastening can fail.

You can install the several modules without additional insulating spacer to one cooler, on condition that voltage between outputs of different modules will not exceed the minimum value of isolation breakdown voltage of each of them or when cooler is grounded.

Connection to module

Connecting of the electrical wires and cables to the power and controlled modules contacts is carried out by soldering. Permissible number of module outputs' re-soldering during electronic (assembly) operations is three. Outputs soldering should be performed at temperature not higher than 235 °C. Soldering duration is not longer than 3 s.

When mounting and operating it is necessary to make protection measures against static electricity impact; on mounting the personnel should use the ground bands and grounded low-voltage soldering irons with transformer supply.

Operating requirements

Module should be used under mechanical loads in accordance with Table 4.1.

Table 4.1 – Mechanical loads impact

External exposure factor	External exposure factor value
Sinusoidal vibration: - acceleration, m/s^2 (g); - frequency, Hz	150 (15) 0.5 - 100
Multiple-acting mechanic shock: - peak shock acceleration, m/s^2 (g); - shock acceleration duration, ms	40 (4) 50
Linear acceleration, m/s^2 (g)	5000 (500)

The module should be used under climatic loads in accordance with Table 4.2.

Table 4.2 – Climatic loads impact

Climatic factor	Climatic factor value
Reduced ambient temperature: - operating, °C; - maximum, °C	- 40 - 45
High ambient temperature: - operating, °C; - maximum, °C	+ 85 + 100
Relative humidity at temperature 35 °C without moisture condensation, %, max	98

Safety requirements

1. Working with the module should only be performed by qualified personnel.
2. Do not touch the power terminals of the module when applying a voltage.
3. Do not connect or disconnect wires and connectors while the power to the circuit module is applying a voltage.
4. Don't touch the module's radiator if it is not grounded and it's applied a voltage.
5. Don't touch the cooler and the module's housing in time its operation thereby their temperature can be very high.
6. Immediately turn off the power supply of the module if it discharges smoke, odor or abnormal noises, check if the module correctly connected.
7. It is not allowed penetrating water and other liquids to the module.

5. RELIABILITY REQUIREMENTS

The manufacturer guarantees the quality of the module all the requirements of the user's manual if the consumer observes terms and conditions of storage, installation and operation, as well as guidance on the application specified in the user's manual.

Operating warranty is 2 years from the acceptance date, in the case of requalification – from the date of the requalification.

Reliability probability of the module for 25000 hours must be at least 0.95.

Gamma percentage life (T_γ) of module at $\gamma = 90\%$ in typical operation conditions should not be less than 50 000 hours within lifetime.

Gamma-percent service life of the modules, subject to cumulative operating time is not more than gamma-percent life, not less than 10 years, at $\gamma = 90\%$.

Gamma-percent storageability time of the modules, at $\gamma = 90\%$ – 10 years.

6. OVERALL AND CONNECTING DIMENSIONS

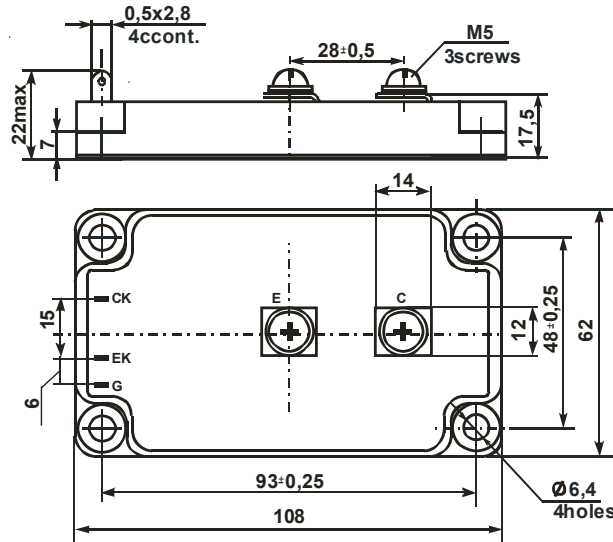

Figure 6.1 – Overall dimensions of modules M9.1

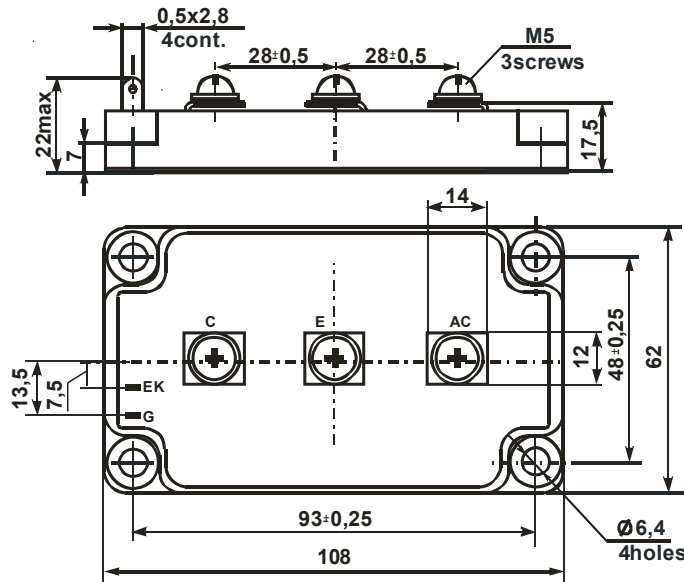

Figure 6.2 – Overall dimensions of modules M10

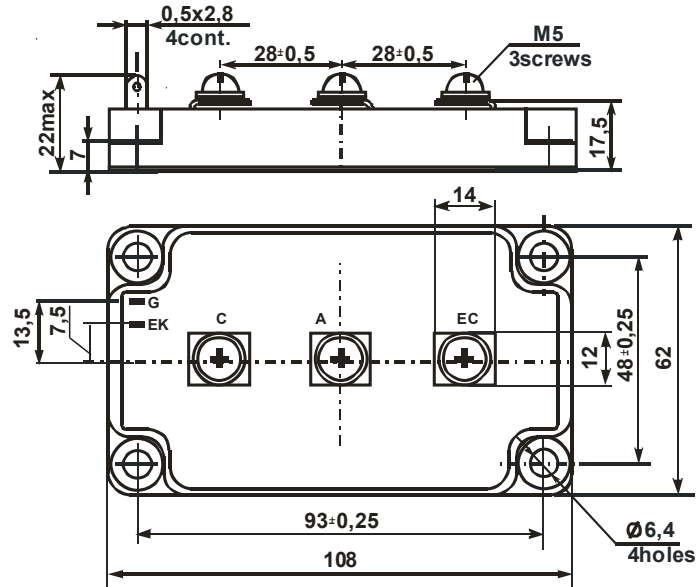

Figure 6.3 – Overall dimensions of modules M11

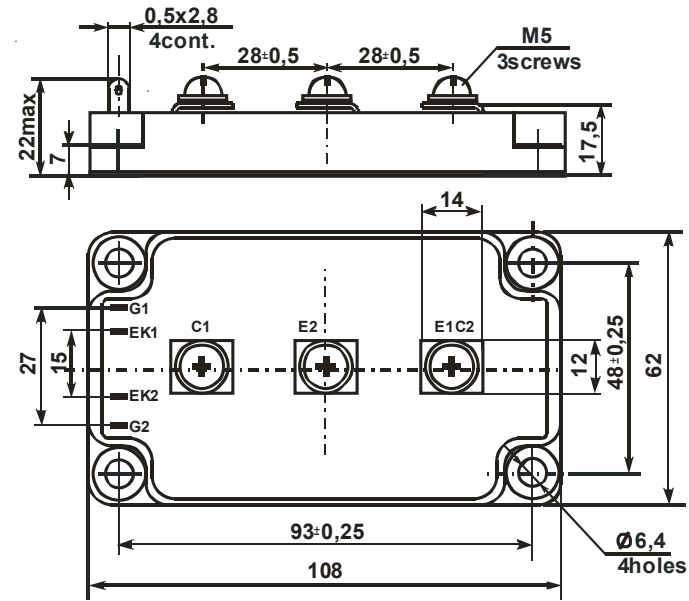

Figure 6.4 – Overall dimensions of modules M12

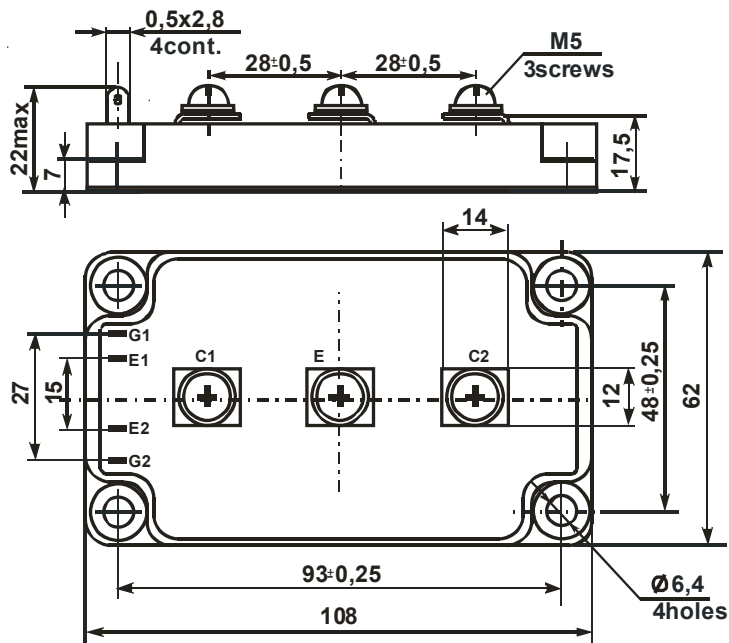

Figure 6.5 – Overall dimensions of modules M12.1

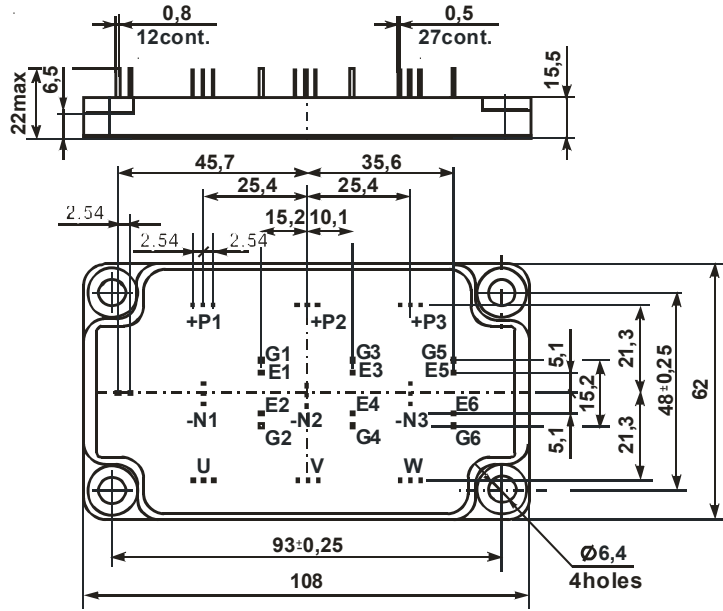

Figure 6.6 – Overall dimensions of modules M13A1

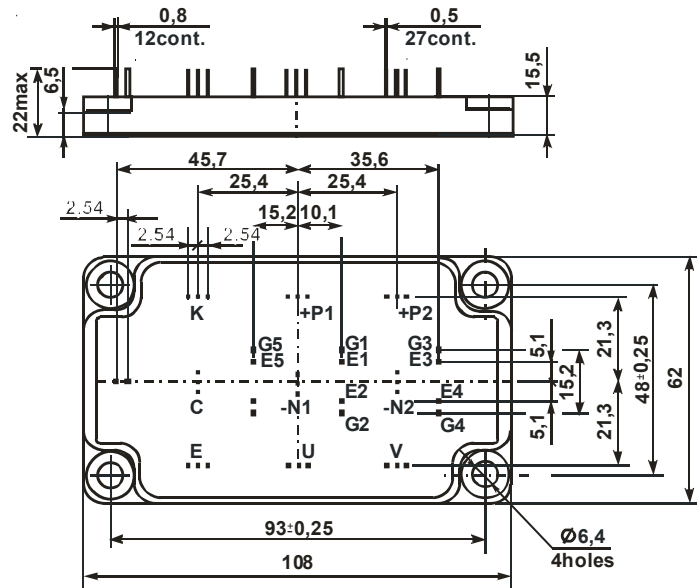

Figure 6.7 – Overall dimensions of modules M13A4

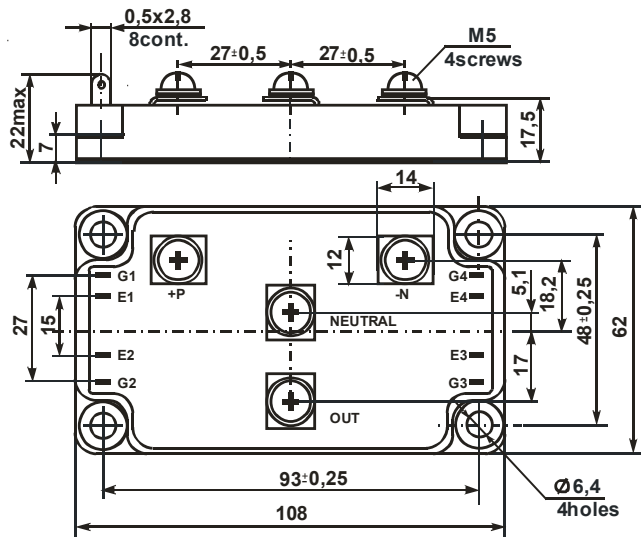

Figure 6.8 – Overall dimensions of modules M13A5

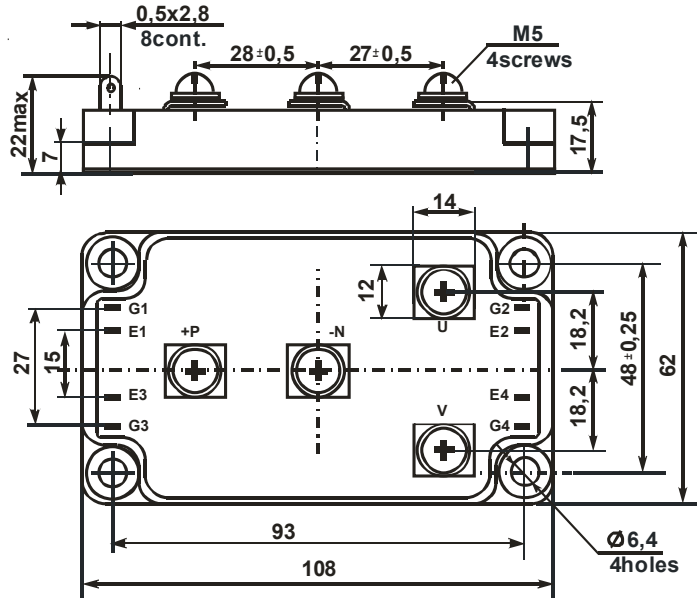

Figure 6.9 – Overall dimensions of modules M13B

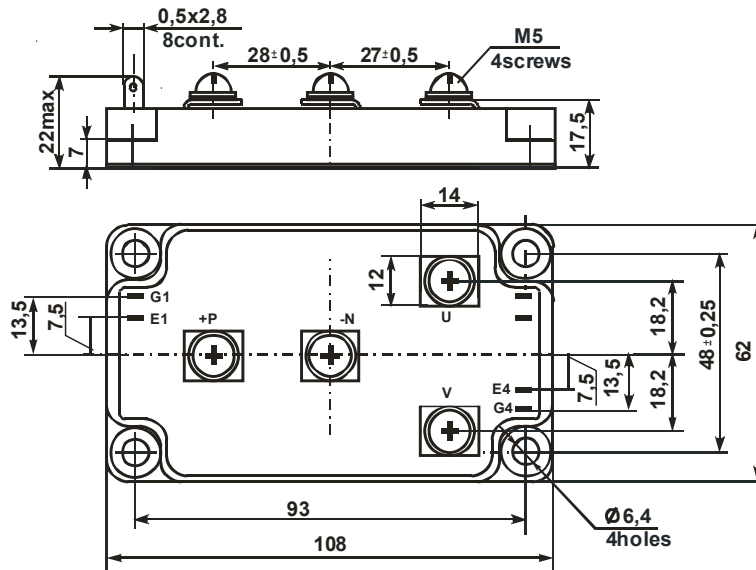

Figure 6.10 – Overall dimensions of modules M13B1

Precious metals are not contained.

5 Naugorskoe highway, Orel, 302020, Russia Tel. +7(4862) 44-03-44, Fax +7(4862) 47-02-12
 E-mail: mail@electrum-av.com