



ELECTRUM AV

www.electrum-av.com

01.01.2013
DR280P-B(B1).doc

IGBT AND MOSFET TRANSISTORS DRIVER DR280P-B, DR280P-B1

USER'S MANUAL

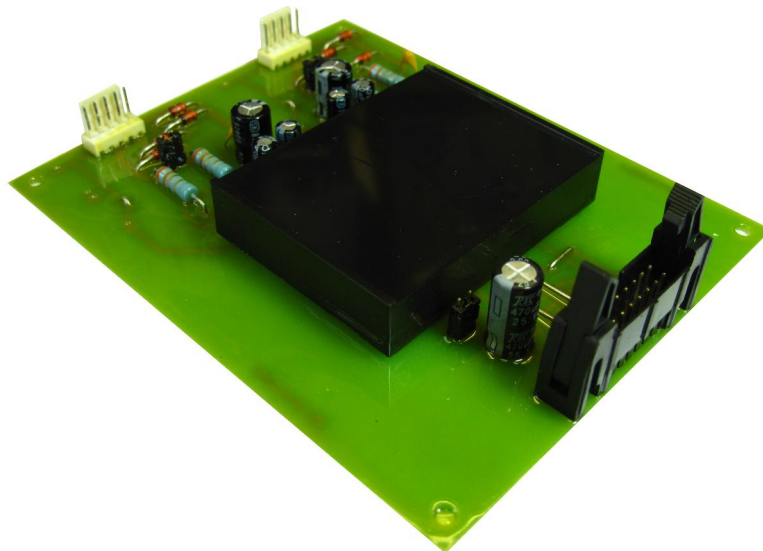

5 Naugorskoe highway, Orel, 302020, Russia Tel. +7(4862) 44-03-44, Fax +7(4862) 47-02-12

E-mail: mail@electrum-av.com

CONTENTS

1 OVERVIEW	3
2 DRIVER COMPOSITION	3
3 FUNCTIONAL DRIVER FEATURES	3
4 BASIC AND MAXIMUM PERMISSIBLE CHARACTERISTICS.....	5
5 DRIVER OPERATION.....	7
6 DRIVER CONNECTION RECOMENDATIONS.....	8
7 GRAPHICS EXPLAINING DRIVER OPERATION	9
8 INFORMATION ABOUT PRECIOUS METALS.....	10
9 SERVICE RECOMMENDATIONS	10
10 RELIABILITY SPECIFICATIONS	11

This document is a user's manual with a description of characteristics of this product for which are warranted. All the products in the production process pass a complete set of electrical tests, which are performed twice, once before encapsulation, and then again after it. Tests carried out by "Electrum AV" are exhaustive and include 100% control at the final testing.

Any such warranty is provided only in accordance with the terms of the supply agreement (supply contract or other documents in accordance with applicable law). The information presented in this document does not provide warranties and liability of "Electrum AV" by the use of such information and the suitability of products for your equipment. The data contained in this document are intended exclusively for technically trained staff. You and your technical expert will have to evaluate the suitability of the product for the application and the completeness of the product data, in connection with this application.

Any products of "Electrum AV" are not permitted for the use in devices and life support systems and special equipment without the prior written consent of "Electrum AV".

If you need information about the product, which is not shown in this user's manual or which concerns the specific application of our product, please contact the sales office to the manager who is responsible for your enterprise.

Engineers "Electrum AV" have a lot of experience in the design, manufacture and application of powerful force devices and smart drivers and has already implemented a large number of individual decisions. If you need power modules and drivers that are not included in the package, as well as products with differences from the standard devices in specifications or design, please contact to our managers and specialists who will offer you best solution for your application.

"Electrum AV" reserves the right to make changes without notice in this document to improve the reliability, functionality and design improvement.

1 OVERVIEW

A two-channel driver of powerful transistors with field control (hereinafter – driver) is intended for dependent galvanic isolated control of two powerful transistors with maximum permissible voltage up to 1700 V. The driver is an amplifier-former of transistors gate control signals with up to 50 kHz. The driver includes built-in galvanic isolated DC-DC converter, providing necessary levels of enabling and blocking voltages on transistor gate.

2 DRIVER COMPOSITION

2.1 The driver – a circuit plate with installed a driver module (DM), performed in hermetic plastic housing, necessary tuning elements and connectors for connection of controlled transistor and control signals.

2.2 The driver contains the following functional parts:

- 1 Supply voltage stabilizer of driver with protection against abnormal turn-on polarity;
- 2 Build-in DC-DC converter with stabilization of enabling and blocking voltage level on controlled transistors gates;
- 3 Input logics;
- 4 Control circuit of control circuit gate;
- 5 Undervoltage and excess voltage protection circuit on controlled transistor gate;
- 6 Controlled transistor protection circuit against overcurrent.

3 FUNCTIONAL DRIVER FEATURES

3.1 The driver provides the following driving, controlling and protecting functions of controlled transistor:

- 1 Saturation voltage control on controlled transistor collector, its protective turn-off when saturation state output;
- 2 Threshold regulation of protective turn-off on saturation voltage;
- 3 Smooth driver junction from active state to inactive one when an emergency (controlled transistor output from saturation mode);
- 4 Control block when an “emergency”
- 5 Emergency signaling;
- 6 Turn-on/off time regulation of controlled transistor by means of resistors resistance change in output circuit (R_{on} , R_{off});
- 7 Simultaneous turn-on block of upper and lower arms;
- 8 Switching delay of upper and lower arms;
- 9 Switching delay regulation of upper and lower arms;
- 10 Driver supply voltage control (built-in comparator) on DC-DC converter output;

3.2 Overall drawing is shown at Figure 1, driver functional circuit and turn-on circuit are presented at Figure 2.

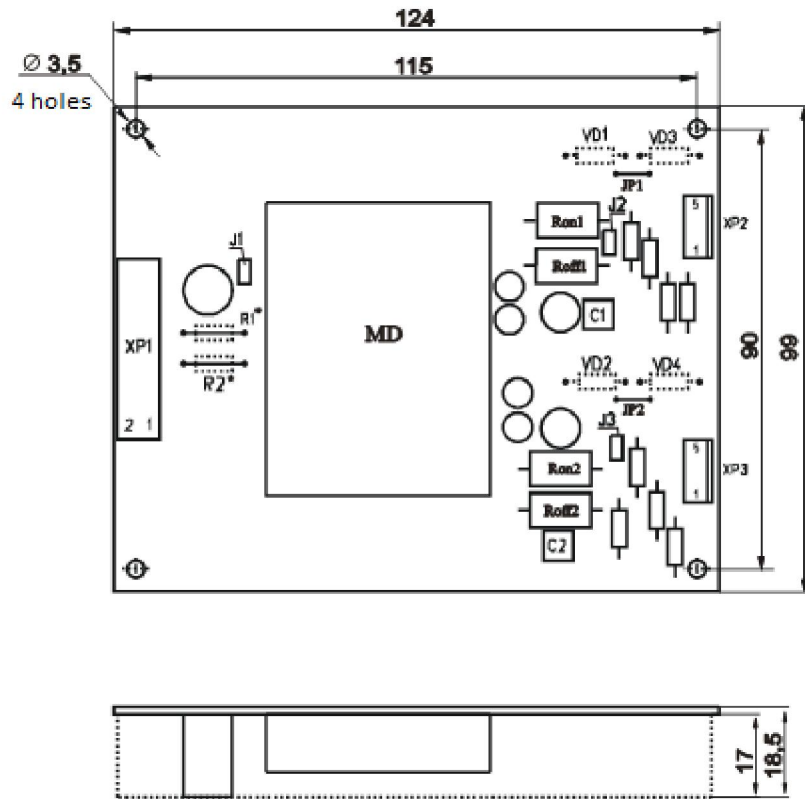

Figure 1 – Driver overall drawing

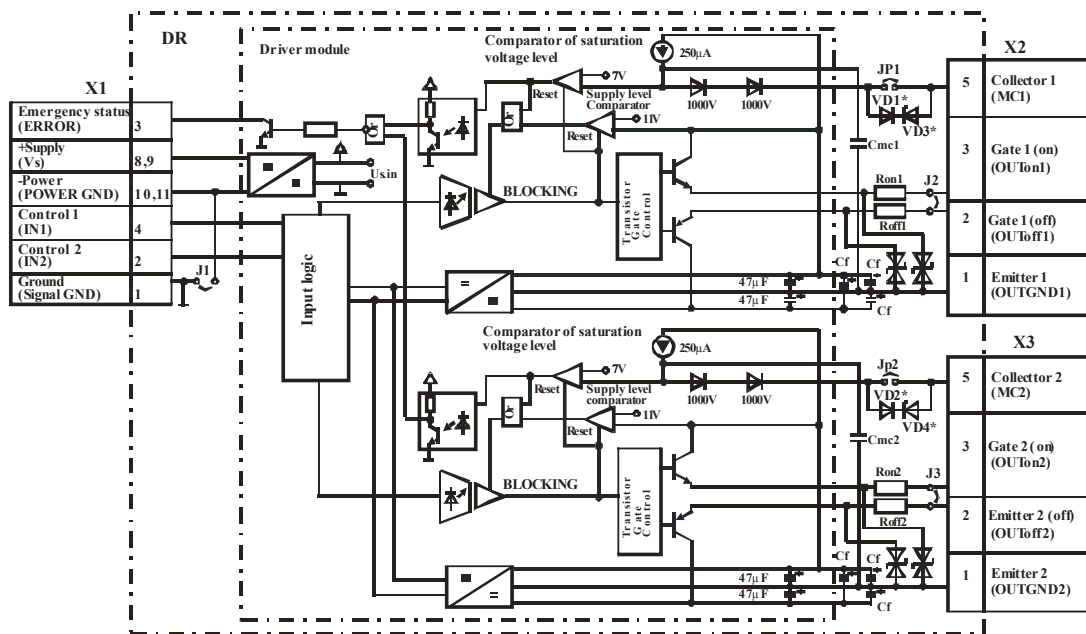

Figure 2– Driver functional and turn-on circuits

Note – Outputs description in accordance with conditionally graphic symbols in electric circuits is shown in the brackets.

X1 – plug IDCC-14MS + socket IDC-14;

X2 – plug WF-M-5 + socket HU-F-5.

3.3 Outputs description is shown in Table 1.

Table 1 – Driver outputs description

Outputs	Outputs description	Symbol
X1.1	Ground signal output for controlling signal delivery	Signal GND
X1.2	Controlling input of channel 2	IN2
X1.3	Error signal output	$\overline{\text{ERROR}}$
X1.4	Controlling input of channel 1	IN1
X1.8, X1.9	Supply +15 V	Vs
X1.10, X1.11	Power ground	POWER GND
X2.1	Output signals ground output 1	OUTGND1
X2.2	Turn-off driver output of channel 1	OUToff1
X2.3	Turn-on driver output of channel 1	OUTon1
X2.5	Measuring collector – saturation voltage control circuit on controlled transistor of channel 1	MC1
X3.1	Output signals ground output 2	OUTGND 2
X3.2	Turn-off driver output of channel 2	OUToff 2
X3.3	Turn-on driver output of channel 2	OUTon2
X3.5	Measuring collector – saturation voltage control circuit on controlled transistor of channel 2	MC2

4 BASIC AND MAXIMUM PERMISSIBLE CHARACTERISTICS

Table 2 – Basic and maximum permissible characteristics (at T = 25 °C)

Characteristic	Symbol	Unit	Value			Note
			min	type	max	
DC/DC block characteristics						
Supply rated voltage	U_S	V	13.5	15	16.5	
Maximum current consumption	I_S	mA			200	f = 0 Hz, see Figures 5 and 6
Power of built-in supply source of output driver module part	P_{DC-DC}	W	4			For each channel
Voltage monitor characteristics						
Turn-off threshold	U_{UVLO+}	V		11		DC-DC output
Turn-on threshold	U_{UVLO-}	V		12		DC-DC output
Control input characteristics						
High level input voltage	U_{IH}	V	3	5	5.6	DR280 P-B
			9	15	16.8	DR280 P-B1
Low level input voltage	U_{IL}	V	-0.6	0	0.8	DR280 P-B
			-0.6	0	2.4	DR280 P-B1
Input resistance	R_{IN}	k Ω		2.0		DR280 P-B
				5.9		DR280 P-B1
Time characteristics						
Signal turn-on delay time between input and output	$t_{d\ on(in-out)}$	μs			0.5	See Figure 14
Signal turn-off delay time between input and output	$t_{d\ off(in-out)}$	μs			0.5	See Figure 14
«Dead time» between signal changes on outputs of first and second channel	t_{TD}	μs		2.5		Set by consumer; see section 6 and Figure 10
Maximum operating frequency	f_{max}	kHz			50	No-load; See section 6 and Figure 5
Block time of fall voltage control on controlled open state transistor	t_{BLOCK1}	μs	5		20	Set by consumer; see section 6 and Figures 3 and 12
Block time of controlled transistor	t_{BLOCK2}	ms		70		See Figure 3

after “emergency”						
Transistor smooth emergency shutdown time	t_{off}	μs		6		See Figure 3
Turn-on delay time of emergency signal	$t_{d(on-err)}$	μs			2	
Output characteristics						
High level output voltage	U_{OH}	V	+14	+16	+19	In all range of permissible loads
Low level output voltage	U_{OL}	V	-7.5	-6	-4	In all range of permissible loads
Maximum output pulse current	I_{Omax}	A	-8		+8	Set by consumer; see section 6 and Figure 8
Mean output current	I_O	mA			160	To each channel
Output signal rise time	t_r	ns			150	No-load, see section 6 and Figures 7, 8 and 14
Output signal fall time	t_f	ns			150	
Maximum current of status output «Error»	$I_{ERR max}$	mA			20	
Maximum voltage of status output «Error»	$U_{ERR max}$	V			30	
Residual voltage on signal output «Error»	U_{OERR}	V	0	0.3	0.7	With $I_{ERR} = 20$ mA
Threshold voltage on measure input MC causing emergency turn-off	U_{Th} U_{MC}	V		5.8		Without additional elements
Isolation characteristics						
Maximum permissible reverse voltage on output «MC»	$U_{R(MC)}$	V			2000	
Isolation voltage between input and output	$U_{ISO(IN-OUT)}$	V			4000	DC, 1 minute
Isolation voltage between inputs first and second channels	$U_{ISO(OUT1-OUT2)}$	V			2000	DC, 1 minute
Critical speed of voltage change on output	$(dU/dt)_{cr}$	kV/ μs			20	
Service and storage characteristics						
Operating temperature range	T_A	$^{\circ}C$	-45		+85	
Storing temperature	T_S	$^{\circ}C$	-60		+100	
Controlled transistor characteristics						
Maximum permissible voltage of controlled transistor	$U_{CE} (U_{DS})$	V			1700	

5 DRIVER OPERATION

Delivery of «log.1» to controlling input «IN1» or «IN2» leads to opening of corresponding controlled transistor. Open state voltage fall increasing by more than U_{ms}^{Th} per time, exceeding t_{BLOCK1} , will lead to protection operation of open state voltage fall increasing (when current overload).

At an “emergency” the transistor will open that is connected in accordance with the scheme with open collector (output «Error»). In 70 ms emergency reset will be performed by internal circuit of emergency reset and on rising edge of control signal «IN» the controlled transistor will be opened. If the emergency cause was not disposed then the protection cycle will recur.

Driver supply voltage decrease to protection operation threshold level against driver supply undervoltage « U_{uvlo} » will lead to closing of controlled transistor regardless of input control signals. Control signals will recover on protection operation threshold against driver supply undervoltage « U_{uvlo+} ». There is not an error signal on output «Error» when protection operation against supply undervoltage.

The both controlled transistors will open when simultaneous delivery of «log. 1» to output «IN1» and «IN2» because the channels operate independently.

Diagram explaining driver operation is shown at Figures 3 and 4.

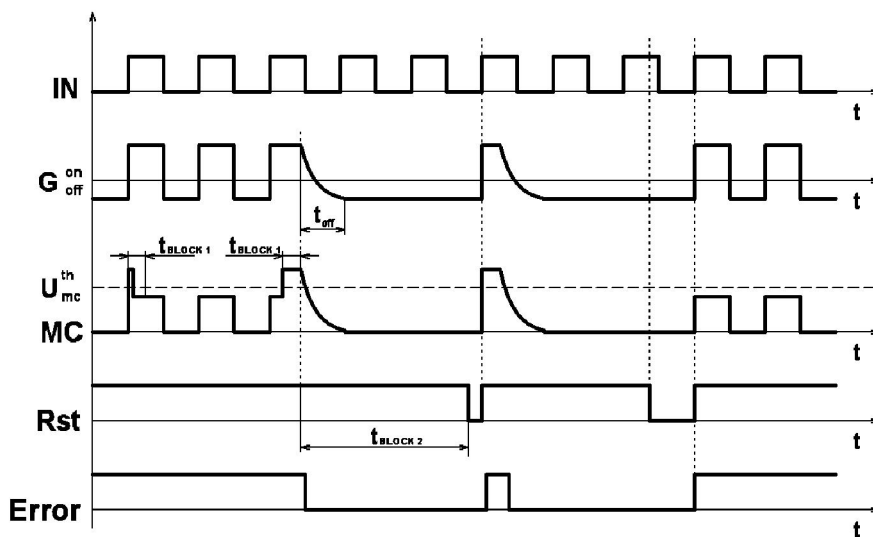

R_{st} – Periodical internal signal of “emergency” reset

Figure 3 – Functional diagram of driver operation at «emergency»

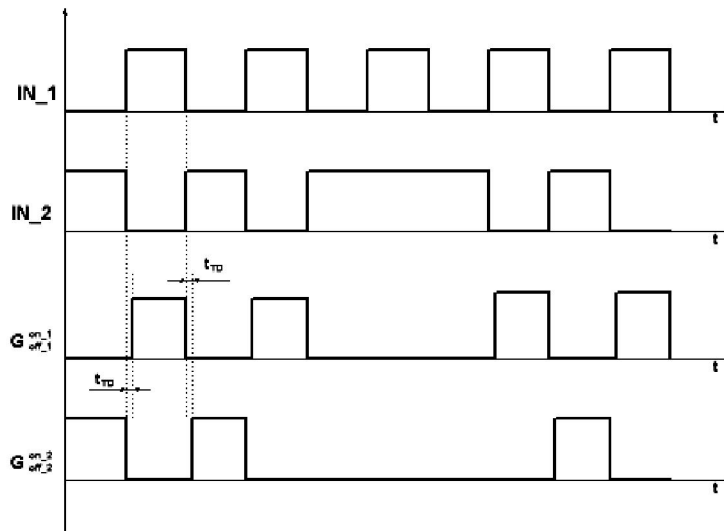

Figure 4 – Functional driver operation diagram

6 DRIVER CONNECTION RECOMENDATIONS

IN, IN2 – controlling inputs. Driver control is described in section «Driver operation». When delivering of controlling voltage you must note that the protective reverse diodes are installed on control inputs. As a result if control voltage exceeds supply voltage by more than 0.6 V then current consumption on inputs will be increased and with considerable increase of supply voltage the driver can fail.

Error – output that signals to emergency. The output is transistor open collector of protection circuit. Meanwhile the transistor will open only when emergency because of power transistor current overload; when driver supply voltage decrease to level « U_{uvlo-} » transistors will be closed regardless of input control signals (the signals will recover when supply level corresponds to « U_{uvlo+} »), but error signaling in this case will not follow. The signaling also will not follow in case of simultaneous delivery of “log. 1” signals to outputs “IN1” and “IN2”, though the output transistors will be closed.

It is not recommended to deliver voltage and current of values higher than maximum permissible, including short-time on output “Error”.

Resistors R1, R2 – timing delay setting resistors for switching of first and second channels. Virtually the resistors regulate turn-on delay time, thereby when resistors setting of different ratings the switching delay on fronts of controlling pulses of first and second channels will be different. When switching delay time increase is not needed, you need to install the jumpers instead of resistors. Delay time versus resistors ratings is shown at Figure 12.

V_S – driver supply output. You must note that when driver supply voltage is decreasing then DC/DC-converter output voltage is also reduced. Thereby if the supply is less than the allowable level then the input circuit can operate faultlessly but on gates of controllable transistors the voltage can drop to level « U_{uvlo-} » and transistor control will be faulty.

Maximum no-load current consumption of supply input is 200 mA. When transistors connecting the current consumption increases by amount of gate recharge current and can reach 750 mA (equal load for both channels). At higher current consumption DC/DC – converter can fail or when short-term current consumption excess in 750 mA, output voltage of DC/DC – converter will decrease to unallowable level and undervoltage protection will operate that will lead to faulty transistor control. In the event of non-uniformly distributed load the current consumption of one channel should not exceed 300mA (without control circuit consumption). Current consumption depends on control signal frequency, resistance value of gate resistors and on gate input capacitance (see Figures 5, 6). Thereby when driver service you must note current consumption correction depending on transistors which the driver will operate on. Driver safe operation area depending on gate capacity and frequency is shown at Figure 8.

MC1, MC2 – collector connection outputs (drain) of controlled transistor. The outputs are intended for voltage fall controlling (saturation protection) on the thyristor. Meanwhile typical protection operation threshold value is equal to 5.8 V (if the external elements are not installed and jumper JP1 and JP2 are installed) or 1 V when jumpers are not installed. Protection operation threshold is regulated by the external elements (Zener diodes and diodes); the voltage drop of Zener diodes and diodes at 250 μ A is deducted from maximum voltage (5.8 V). For instance, if you install the Zener diode sequentially with rated Zener breakdown 3.3 V and two diodes with voltage drop 0.7 V at 250 μ A, then protection operation threshold will be equal to $5.8-3.3-2 \times 0.7=1.1$ V.

In the case if current overload protection of controlled transistor is not required, then «MC» output should be short-circuited to source (emitter) of corresponding channel.

Condensers C_{mc1}, C_{mc2} – timing condensers that form turn-off delay of corresponding controlled transistor when current overload. Protection operation delay is necessary to avoid malfunction of short-time inductive kicks. Thereby in case of emergency this delay time will be equal to “rerun pulse” continuance. To increase protection operation delay, it is recommended to install the condensers with ratings indicated at Figure 11. Initially it is installed the condenser with capacity 100 pF that corresponds to delay continuance of 8 μ s (typ.).

OUToff1, OUToff2, OUTon1, OUTon2 – outputs intended for connecting of controlled transistors gates.

Gate transistors (Ron1, Ron2, Roff1 and Roff2) are necessary for decrease of maximum pulse current. It is not recommended to install the resistors with ratings less than 1 Ω . It is allowed to install the resistors with different ratings, for instance, for increase of controlled transistor turn-off continuance to decrease voltage amplitude of inductive kicks.

Jumpers

JP1, JP2 – jumpers regulating saturation protection operation threshold of controlled transistors. With installed jumpers the saturation voltage protection operation threshold of transistor $U_{ms}^{Th} = 5.8 \text{ V}$. When jumpers are not installed, protection operation threshold is equal to 1 V.

Note – If it is necessary to change jumper JP1 the method of hand soldering by electric soldering iron with temperature of solder stick $(245 \pm 15) \text{ }^\circ\text{C}$ with use of solder alloy and resin flux. In case of rosin-core solder and soldering paste use there is no necessity in additional fluxing.

J1 – jumper combined «minus» of power and «ground» of driver control;

J2, J3 – jumper combined resistors R_{on1} and R_{off1} , R_{on2} and R_{off2} for connection to the gate.

7 GRAPHICS EXPLAINING DRIVER OPERATION

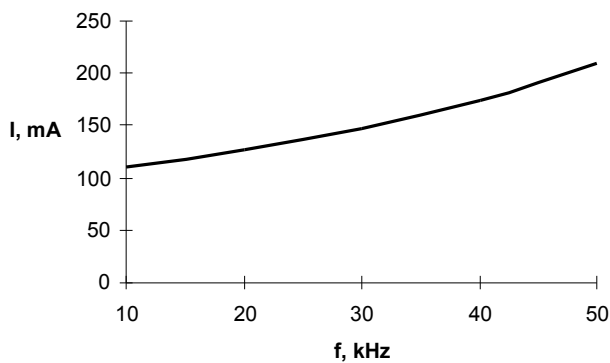

Figure 5 – Graph of driver current consumption versus no-load control signal frequency

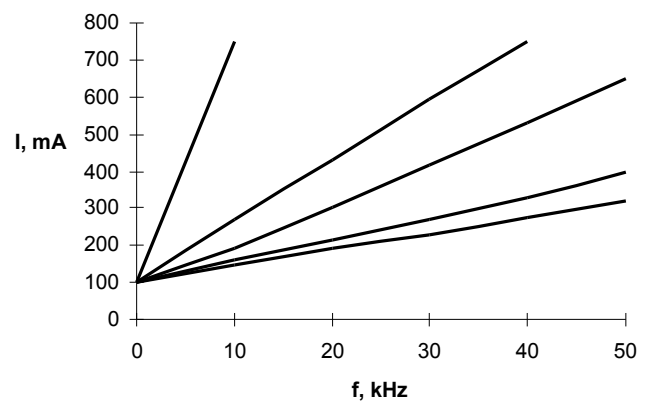

Figure 6 – Graph of current consumption versus signal frequency under load (with gate resistor 5Ω) for gate capacities 10 nF, 25 nF, 50 nF, 100 nF and 250 nF

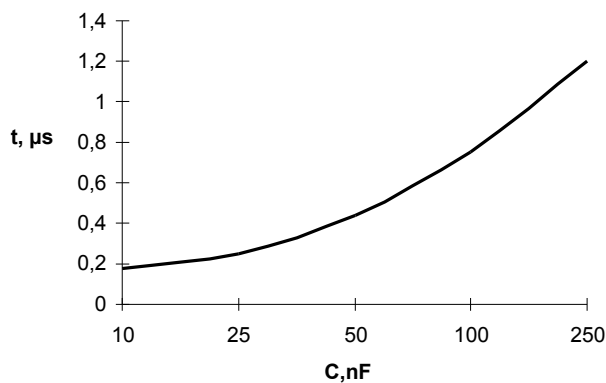

Figure 7 – Graph of acceleration time versus gate capacity (with gate resistor 5Ω)

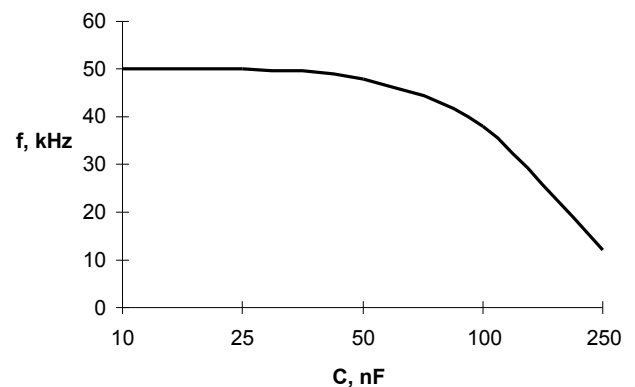

Figure 8 – Graph of driver safe operation area (with gate resistor 5Ω)

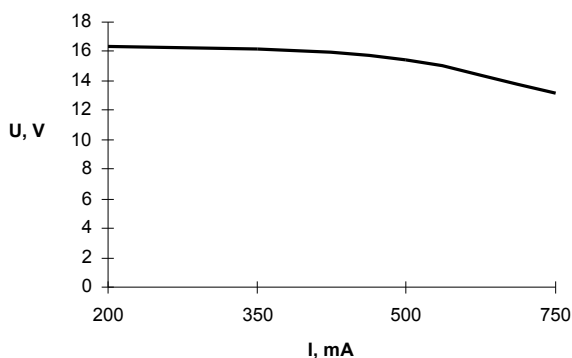

Figure 9 – Graph of transistor gate voltage versus

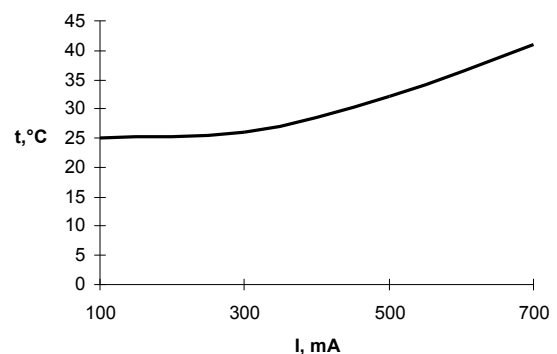

Figure 10 – Graph of driver housing temperature

current consumption

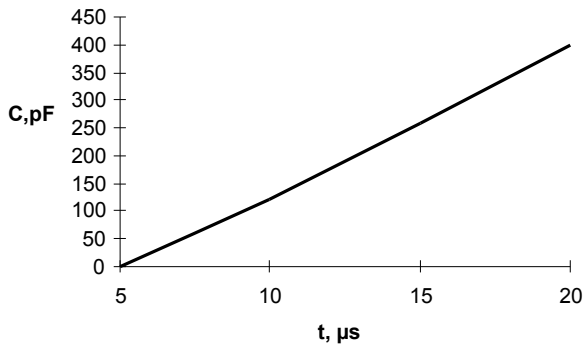

Figure 11 – Graph of delay continuance of saturation protection turn-on versus trimmer capacity

versus current consumption

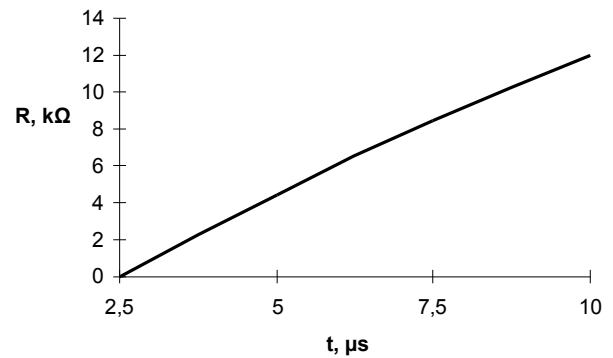

Figure 12 – Graph of switching delay time versus trimmer resistors rating

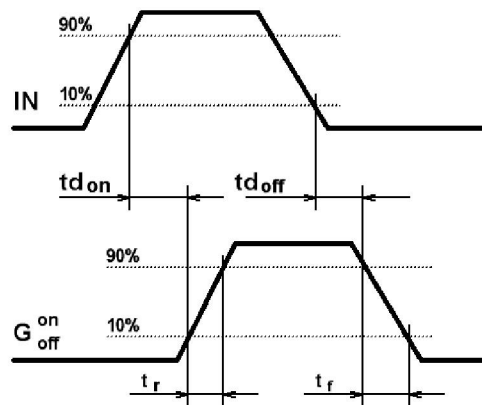

Figure 13 – Diagram explaining driver time characteristics where IN – input control signal; G – signal on controlled transistor gate

8 INFORMATION ABOUT PRECIOUS METALS

Precious metals are not contained.

9 SERVICE RECOMMENDATIONS

9.1 Tolerance requirements at mechanical impacts

Mechanical impacts for drivers in accordance with qualifying standards of controlled power transistors are shown in Table 3.

Table 3 – Drivers tolerance requirements to mechanical impact factors

External exposure factors	External exposure factor value
Sinusoidal vibration:	
- frequency range, Hz;	0.5 - 100
- acceleration amplitude, m/s^2 (g)	150 (15)
Mechanical shock of single action:	
- peak shock acceleration, m/s^2 (g);	40 (4)
- pulse duration of shock acceleration, ms	50

9.2 Tolerance requirements at climatic impacts

Climatic impacts in accordance with qualifying standards of controlled power transistors are shown in Table 4.

Table 4 - Tolerance requirements to climatic impact factors

Climatic factor	Climatic factor value
Lower ambient temperature: - operating, °C; - maximum, °C	minus 45 minus 60
Higher ambient temperature: - operating, °C; - maximum, °C	+85 +100
Relative humidity with temperature 35 °C without moisture condensation, %, max	98
Ambient temperature change, °C	from minus 60 to +100

10 RELIABILITY SPECIFICATIONS

The manufacturer guarantees the quality of the module all the requirements of the user's manual if the consumer observes terms and conditions of storage, mounting and operation, as well as guidance on the application specified in the user's manual.

Operating warranty is 2 years from the acceptance date, in the case of requalification – from the date of the requalification.

Reliability probability of the driver for 25000 hours must be at least 0.95.

Gamma-percent life must be not less than 50000 hours by $\gamma = 90\%$.

Gamma-percent service life of the modules, subject to cumulative operating time is not more than gamma-percent life, not less than 10 years, at $\gamma = 90\%$.

Gamma-percent storageability time of the modules, at $\gamma = 90\%$ and storing – 10 years.

5 Naugorskoe highway, Orel, 302020, Russia Tel. +7(4862) 44-03-44, Fax +7(4862) 47-02-12

E-mail: mail@electrum-av.com