

MODULE OF TWO MOSFET SWITCHES M12-300-2-M1

USER'S MANUAL

1 GENERAL DESCRIPTION

A module of two series-connected MOSFET switches shunted by a reverse FRD M12-300-2-M1 (hereinafter - module), is intended to commutate power loads and to use it as a part of power converters with high switching frequency. The module is an analogue of power modules APTM20AM04FG produced by «Microsemi» in housing of kind SP6.

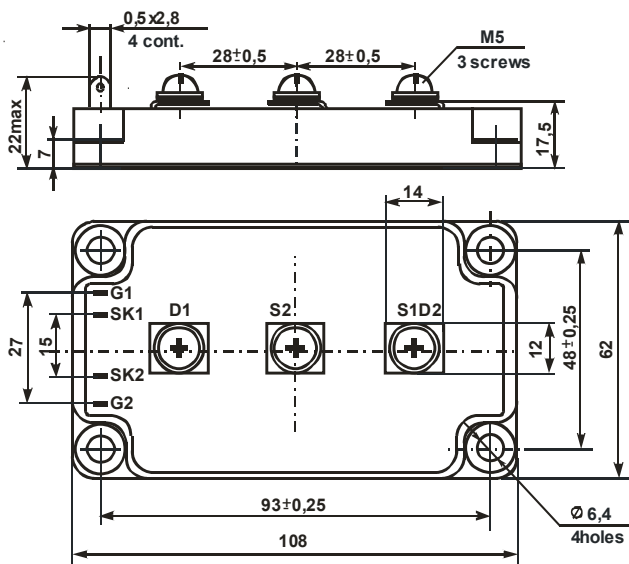

Figure 1 – Overall and connecting module's dimensions

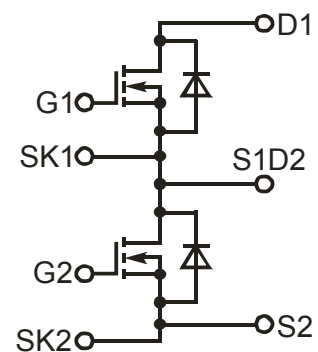

Figure 2 – Electric circuit of internal module's connections

2 TECHNICAL CHARACTERISTICS

2.1 Electric parameters are represented in Table 1.

Table 1 – Basic and maximum permissible modules' parameters

Parameter name, Unit	Symbol	min	typ.	max	Measuring condition
Basic characteristics					
Drain-source breakdown voltage, V	$V_{(BR)DSS}$	200			$V_{GS}=0\text{ V}; I_D=1\text{ mA}$
Direct voltage of power circuit, V	V_{DC}			130	
DC of power circuit (max), A	I_{DC}			300	
Insulation strength, (DC), V	V_{ISOL}	1000			DC, 1 minute
Thermal resistance junction – case, °C/ W	$R_{T(j-c)} VT$			0.1	
Dissipation power (max), W	P_D			1500	$T_c=25\text{ °C}$
Static characteristics					
Gate-source threshold voltage, V	$V_{GS(th)}$	2		4	$I_D=1.5\text{ mA};$
Gate leakage current, nA	I_{GSS}			±500	
Drain-source open state resistance, mΩ	$R_{DS(on)}$			6	$I_D=300\text{ A}$
Начальный ток стока, мкА	I_{DSS}			200	$V_{DS}=200\text{ V}$
Dynamic characteristics					
Input capacitance, pF	C_{ies}		27600		$f=1\text{ MHz}; V_{DS}=25\text{ V}$
Output capacitance, pF	C_{oes}		2760		
Transfer capacitance, pF	C_{res}		600		

Switching-on delay duration, ns	$t_{d(on)}$		40		$V_{DS}=100\text{ V}$ $I_D=300\text{ A}$
Rise duration, ns	t_r		60		

Continuation of Table 1

Parameter name, Unit	Symbol	min	typ.	max	Measuring condition
Switching-on delay duration, ns	$t_{d(off)}$		50		$V_{DS}=100\text{ V}$ $I_D=300\text{ A}$
Fall duration, ns	t_f		50		
Total gate charge, nC	Q_G			600	
Reverse diode characteristics					
Direct voltage fall, V	V_{SD}			1.3	$V_{GS}=0\text{ V}; I_{SD}=300\text{ A}$
Diode DC, A	I_S			300	
Diode pulse current, A	I_{SM}			9600	$t_{HMT}=1\text{ ms}$
Reverse recovery current, A	I_{RR}		224		
Recovery duration, ns	t_{RR}			220	
Maximum permissible modes					
Drain-source voltage, V	V_{DSS}			200	
Gate-source voltage, V	V_{GS}			± 20	
Drain DC, A	I_D			420	$T_c=25\text{ }^\circ\text{C}$
Drain DC, A	I_D			300	$T_c=100\text{ }^\circ\text{C}$
Drain pulse current, A	I_{DM}			1200	$T_{pul}=1\text{ ms}$
Junction temperature, $^\circ\text{C}$	T_j^*			175	

3 INSTRUCTIONS FOR USE

General requirements

It is recommended operating the module at operating average current value not more than 80% from specified in the name and junction temperature not more than (70÷80)% from the maximum.

It is not allowed the module operating at modes when simultaneous impact of two or more maximum permissible parameters.

In the electric installation circuit with use of the modules should be provided a fast-speed protection against unallowable loads, short circuits and commutation overloads.

Module mounting

The module is mounted in the equipment on cooler (chassis, application housing, metal plates, etc.) in any orientation with screws M6 with torque (5±0.5) N·m, with obligatory installation of flat and spring washers. The module should be located in such a way to protect it against additional heat from neighboring elements. The planes of cooler ribs should be oriented in the direction of air flow.

The contact area of the cooler should have roughness not more than 2.5 μm and flatness tolerance – not more than 30 μm . The cooler surface should not have any rough edges, honeycombs. There should not be extraneous particles between the module and the cooler. To improve the heat balance the module installation to mounting area or cooler should be carried out using heat conducting pastes.

When mounting, you should provide uniform pressure of module housing to cooler. For this purpose you should tighten all screws in 2 – 4 motions by turns: first, located on one diagonal, then on the other one. When disassembling the module the screws tightening should be done in reverse order.

Not earlier than in 3 hours after mounting the screws should be rotated to the end keeping the prescribed torque, because the part of the heat conducting paste under pressure will outflow and the fastening can fail.

You can install on the same cooler several modules without additional insulating spacers, on condition that the voltage between outputs of different modules will not exceed the minimum value of isolation breakdown voltage of each of them or when the cooler is grounded.

Connection to module

Electric wires and cables will be connected to power contacts of the module by means of screws M5 with torque (4 ± 0.5) N·m and the washers that are supplied in the pack. For the modules M13A1, M13A4 connection of the power circuits are carried out using soldering. Also using soldering is carried out the connection of the controlled connectors. The outputs soldering should be performed at temperature not higher than (235±5) $^\circ\text{C}$. Soldering duration is not more than 3 sec. The permissible number of module outputs' re-soldering during mounting (assembly) operations is three.

The connection of power wires should be performed via connectors having anti-corrosion covering, cleaned from extraneous accretions. When screws (bolts) are tightened it is recommended to fasten the connection with paint. It is recommended to tighten screws (bolts) repeatedly in 8 days and in 6 weeks after commencement of operating. Afterwards gripping should be controlled at least once a half year.

When mounting and operating it is necessary to make protection measures against static electricity impact and overvoltage in gate circuit; on mounting the personnel should use ground bands and grounded low-voltage soldering irons with transformer supply.

Operation requirements

The module should be used under mechanical loads according to Table 2.

Table 2 – Mechanic loads impacts

External exposure factor	External exposure factor value
Sinusoidal vibration: - acceleration, m/s ² (g) - frequency, Hz	150 (15) 0.5 - 100
Multiple-acting mechanic shock: - peak shock acceleration, m/s ² (g) - shock acceleration time, ms	40 (4) 50
Linear acceleration, m/s ² (g)	5000 (500)

The module should be used under climatic loads according to Table 3.

Table 3 – Climatic loads impacts

Climatic factor	Climatic factor value
Reduced ambient temperature: - operating, °C - maximum, °C	- 40 - 45
High ambient temperature: - operating, °C - maximum, °C	+ 85 + 100
Relative humidity at temperature 35 °C without moisture condensation, %, max	98

Safety requirements

1. Operation with the module should be carried out only by qualified personnel.
2. Do not touch the module power outputs of the supply voltage applied.
3. Do not connect or disconnect wires and connectors while on the power circuit is energized.
4. If the radiator is not grounded, do not touch it, if the module is filed by force feeding.
5. Do not touch the radiator or discharge resistance because its temperature can be very high.
6. If the module is smoking, smelling or abnormal noising, immediately turn off the power and contact to the manufacturer.
7. Avoid contacting to the module with water and other liquids.

4 RELIABILITY REQUIREMENTS

The manufacturer guarantees the quality of the module all the requirements of the user's manual if the consumer observes terms and conditions of storage, mounting and operation, as well as guidance on the application specified in the user's manual.

Operating warranty is 2 years from the acceptance date, in the case of requalification – from the date of the requalification.

Reliability probability of the driver for 25000 hours must be at least 0.95.

Gamma-percent life must be not less than 50000 hours by $\gamma = 90\%$.

Gamma-percent service life of the modules, subject to cumulative operating time is not more than gamma-percent life, not less than 10 years, at $\gamma = 90\%$.

Gamma-percent storageability time of the modules, at $\gamma = 90\%$ and storing – 10 years.