

**DRIVERS OF THREE-PHASE REGULATED RECTIFIER FOR  
LOW-VOLTAGE SUPPLY CIRCUITS WITH RMS VOLTAGE 27V  
3phCRD-A1-400-01, 3phCRD -A2-400-01, 3phCRD -A3-400-01, 3phCRD -A4-400-01,  
3phCRD -A5-400-01,  
3phCRD -B1-400-01, 3phCRD -B2-400-01, 3phCRD -B3-400-01, 3phCRD -B4-400-01,  
3phCRD -B5-400-01**

**TECHNICAL DESCRIPTION**

A driver of three-phase regulated rectifier (3phCRD-400-01) is intended to control by three-phase thyristor-diode bridge in three-phase regulated rectifier. The driver is intended to operate in circuits of three-phase AC with frequency 400 Hz, with linear voltage 24 or 27 V.

In the 3phCRD-400-01 is used a vertical-pulse method to adjust the rectified voltage; at this method adjusting of the value of rectified voltage on load is performed by changing the duration of thyristors on-state.

Functional circuit of 3phCRD-400-01 is shown on Figure 1.

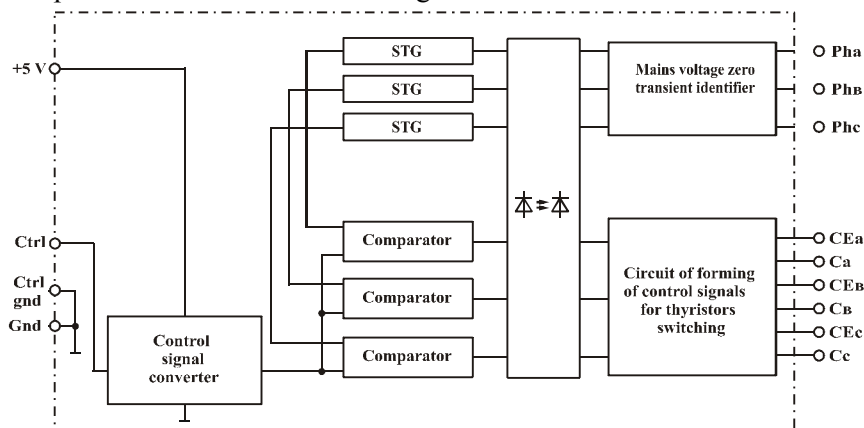
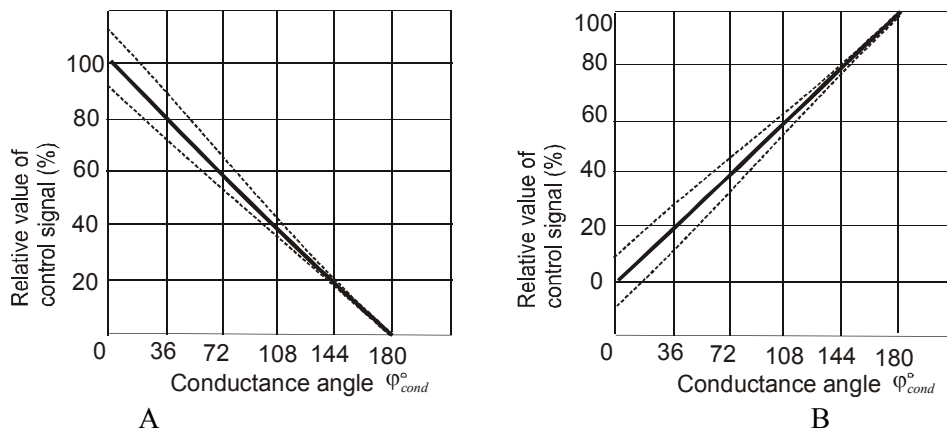

Figure 1 – Functional circuit of 3phCRD-400-01

Voltage zero transient identifier forms pulses during line voltage zero transient, which synchronize three-channel sawtooth generator (STG). In the three-channel comparator it is compared the voltage of STG and controlling signal given from the circuit of converter of the input signal. If the voltage of STG and the control signal voltage are matched, then a pulse for switching of external thyristors is generated. Adjusting of the input voltage is carried out by changing duration of on-state of power thyristors.

The 3phCRD-400-01 is controlled by an external signal of one of five types (0...5 V; 0...10 V; 0...5 mA; 0...20 mA; 4...20 mA). The 3phCRD-400-01 is produced in one of two kinds of dependence of thyristors' conduction angle on relative value of the control signal. Dependences of thyristors conduction angle versus relative value of the control signal are shown on Figure 2.



A – 100% control signal corresponds to minimum load voltage;  
B – 100% control signal corresponds to maximum load voltage.

Figure 2 – Control characteristics types

Basic technical characteristics are represented in Table 2.

Table 2 – Basic technical characteristics

Parameters name	Unit	Kinds and types of input circuits										Note	
		A-1	A-2	A-3	A-4	A-5	B-1	B-2	B-3	B-4	B-5		
Basic electrical parameters													
1 Current consumption, max	mA	50										Usup = 5 V	
2 Control signal value corresponding to minimum voltage on load	V	5±0.5	10±1	-	-	-	0÷0.5	0÷1	-	-	-		
	mA	-	-	20±2	5±0.5	20±2	-	-	4±0.4	0÷0.5	0÷2		
3 Control signal value corresponding to maximum voltage on load	V	0÷0.5	0÷1	-	-	-	5±0.5	10±1	-	-	-		
	mA	-	-	4±0.4	0÷0.5	0÷2	-	-	20±2	5±0.5	20±2		
4 Resistance of control signal input circuit	kΩ	≥10	≥10	-	-	-	≥10	≥10	-	-	-		
5 DC insulation voltage	V	4000	4000	4000	4000	4000	4000	4000	4000	4000	4000	1 minute	
Maximum permissible values of basic parameters													
1 Supply voltage	min	V	4.5										
	max	V	5.5										
2 Input voltage «Ctrl»	max	V	6	12	2	2	2	6	12	2	2	2	
3 Peak voltage value on inputs «Pha», «PhB», «Phc»	max	V	200									tp ≤ 10 μs	
4 Rated value of linear voltage on inputs «Pha», «PhB», «Phc»	min	V	18										
	max		36										
5 Output current on control output	min	A	1									tp ≤ 50 μs	
6. Frequency of three-phase network		Hz	400									±10 %	
7. Operating temperature range		°C	-40...+80										

Outputs application is shown in Table 1.

Table 1 –Outputs application of 3phCRD-400-01

Socket	Output #	Symbol	Application
XS1		Pha	Input of phase A of AC power network
XS2		CEa	Connection of controlling thyristor electrode
XS3		Ca	Connection of thyristor cathode
XS4		PhB	Input of phase B of AC power network
XS5		CEB	Connection of controlling thyristor electrode
XS6		CB	Connection of thyristor cathode
XS7		Phc	Input of phase C of AC power network
XS8		CEc	Connection of controlling thyristor electrode
XS9		Cc	Connection of thyristor cathode
XS10	1	Gnd (-5 V)	Common «minus» of supply circuits
	2	+5 V	Supply voltage +5 V
	3	Ctrl gnd	«Minus» of control signal
	4	Ctrl	Input of control signal

Overall drawing of 3phCRD-400-01 is shown on Figure 3.

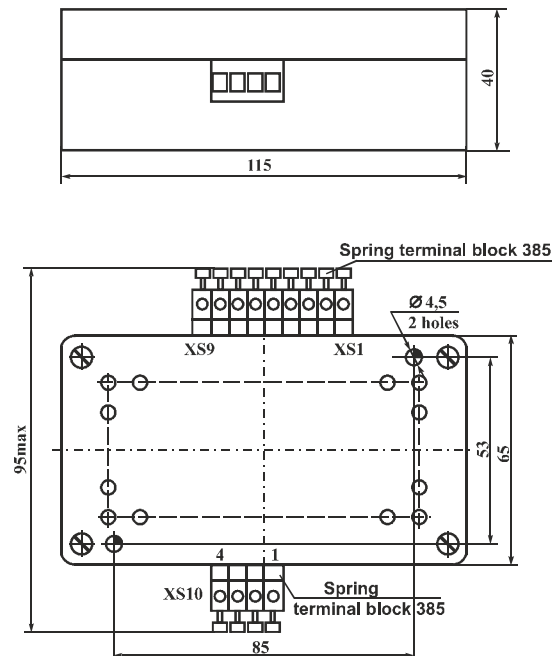

Figure 3 – Overall drawing of 3phCRD-400-01

Symbols system:  $\frac{3\text{phCRD}}{1} - \frac{A}{2} - \frac{1}{3} - \frac{400}{4} - \frac{01}{5}$

- 1 Driver name
- 2 Control characteristics:
  - A - 100% control signal correspond to minimum voltage;
  - B - 100% control signal correspond to maximum voltage.
- 3 Control signal type:
  - 1 - 0...5 V;
  - 2 - 0...10 V;
  - 3 - 4...20 mA;
  - 4 - 0...5 mA;
  - 5 - 0...20 mA.
- 4 Frequency of three-phases.
- 5 Design version

### Connection recommendation

Connection circuits of the 3phCRD-400-01 are shown on Figures 4 – 6.

As closer as you can the 3phCRD-400-01 should mount to the controlled bridge but only not on cooler which it is mounted on. When mounting it is not allowed to lay the wires of power line and control circuits all in one harness or in common pipe (ducting). Avoid loops in the connecting wires of control and supply circuits. The connecting control wires should make as twisted-pair wires to provide noise immunity.

**Attention! When connecting it is necessary to provide exact phases sequence.**

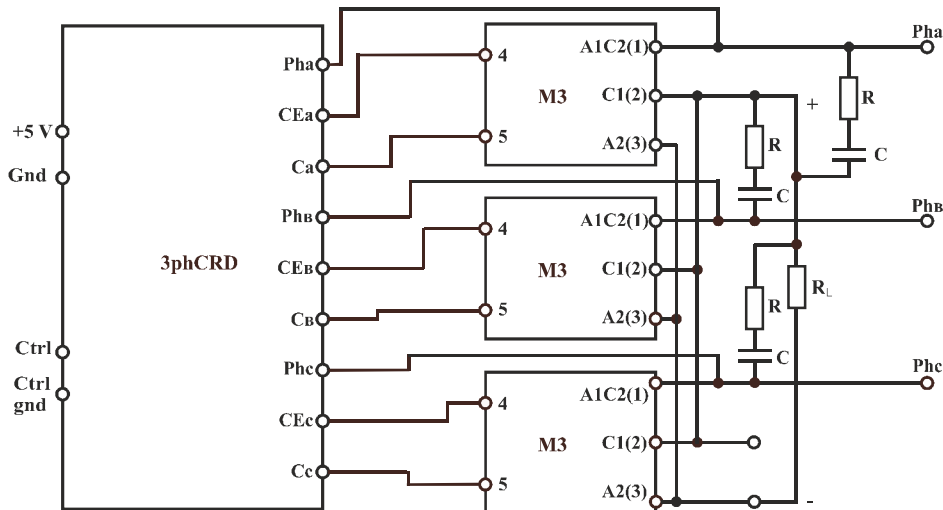

Figure 4 – Connection circuit of 3phCRD-400-01 to bridge based on modules M3

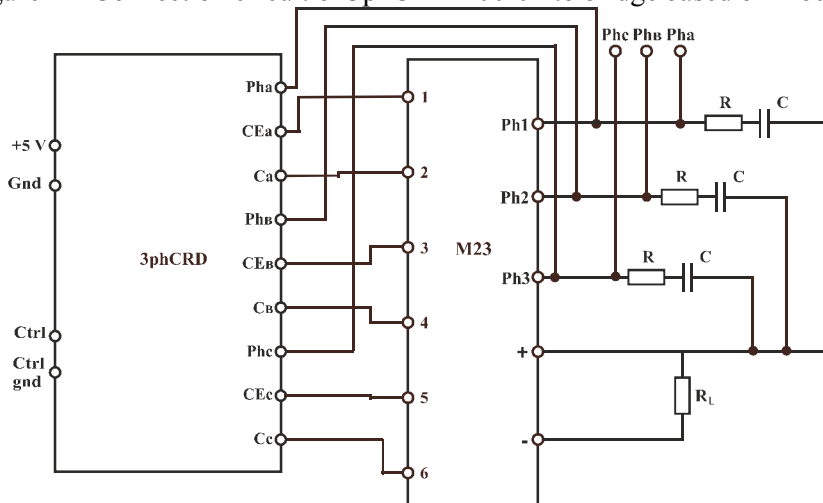

Figure 5 – Connection circuit of 3phCRD-400-01 to bridge M23

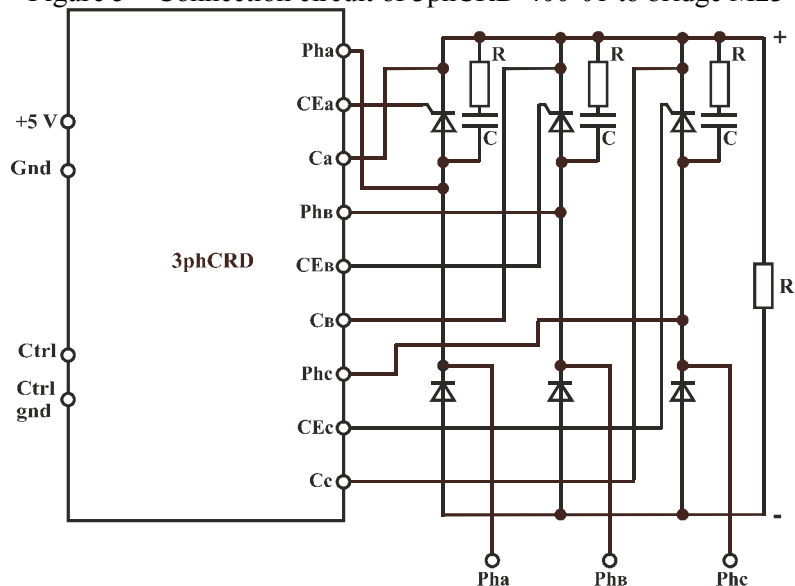

Figure 6 – Connection circuit of 3phCRD-400-01 to diode-thyristor modules

It is necessary to shunt the module by RC circuits for improving resistance to  $dU/dt$  (see Fig. 4, 5, 6).

5 Naugorskoe shosse, Orel, 302020, Russia Tel. +7(4862) 44-03-44, Fax +7(4862) 47-02-12  
E-mail: [mail@electrum-av.com](mailto:mail@electrum-av.com)